



MEADE[®]

www.meade.com

MEADE INSTRUCTION MANUAL

AdventureScope Telescope Series



AdventureScope



WARNING!

Never use a Meade® Telescope to look at the Sun!

Looking at or near the Sun will cause instant and irreversible damage to your eye. Eye damage is often painless, so there is no warning to the observer that damage has occurred until it is too late. Do not point the telescope at or near the Sun. Children should always have adult supervision while observing.

TABLE OF CONTENTS

Introduction.....	2
Parts Included.....	2
Features.....	3
Setting up the Telescope.....	4
Attaching the Scope to the Tripod.....	4
Attaching the Accessories.....	5
Using the Telescope Controls.....	5
Using the Red Dot Finder.....	6
Looking Through the Eyepiece.....	6
What to Look At?.....	6
Terrestrial Observations.....	6
Celestial Observations.....	7
Some Observing Tips.....	10
Taking Care of Your Telescope.....	12
Specifications.....	13
Changing the Viewfinder Battery.....	14
Optional Accessories.....	14
Meade Customer Service.....	15
Meade Limited Warranty.....	15
Recycling information.....	16
Observing Logs.....	17



Never use the AdventureScope to look at the Sun!

Looking at or near the Sun will cause instant and irreversible damage to your eye. Eye damage is often painless, so there is no warning to the observer that damage has occurred until it is too late. Do not point the Adventure scope or its viewfinder at or near the Sun. Children should always have adult supervision while observing.

Introduction

Meade's Adventure scopes are ideal for high-magnification, high resolution observation of terrestrial subjects. Explore the subtleties of a bird's feather structure from 50 yards or use the Adventure scope for casual astronomical observations of the night sky.

Note: "Adventure Scope" is intended for terrestrial (land) viewing. However, the Adventure Scopes can also be used for casual astronomical observing.

Parts Included

The following parts are included with the Adventure scope:

- Optical tube
- Tripod
- Soft carry backpack
- Two 1.25" Eyepieces
- Red dot finder
- Backpack

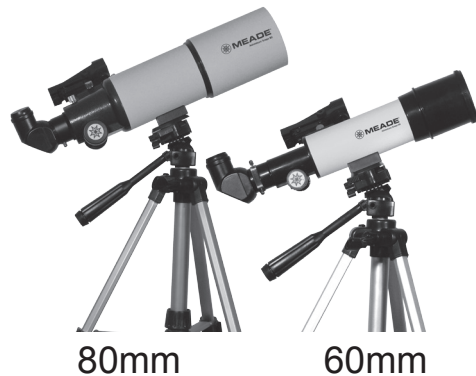

Features

Figure 1A: Features of the Meade AdventureScope

1. Front Dust Cover
2. Dew Shield
3. Optical Tube (OTA)
4. Red Dot Finder
5. Focuser
6. Focuser Thumbscrews
7. Eyepiece
8. Erect-Image Thumbscrew
9. 90 Degree Erect-Image Diagonal
10. Focusing Adjustment
11. Mounting Shoe
12. Pan Handle
(Vertical Motion Lock)
13. Center Column
14. Center Column Adjustment Handle
15. Tripod
16. Tripod Head
17. Center Column Lock Knob (not visible)
18. Bubble Level
19. Azimuth Lock Knob
(Horizontal Motion Lock)
20. Tripod Leg Lock
21. Leg Struts
22. Tripod Center Lock
23. Quick Release Latch
24. 90 Degree Tilt Lock

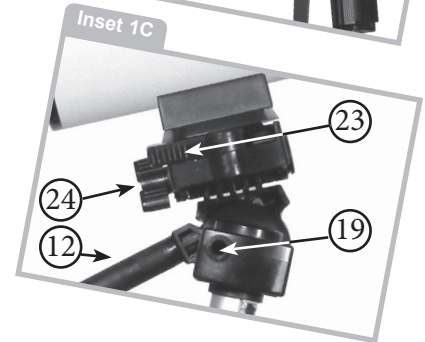
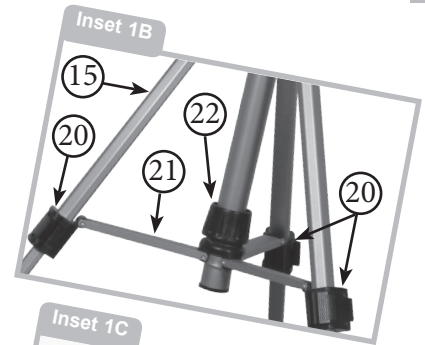
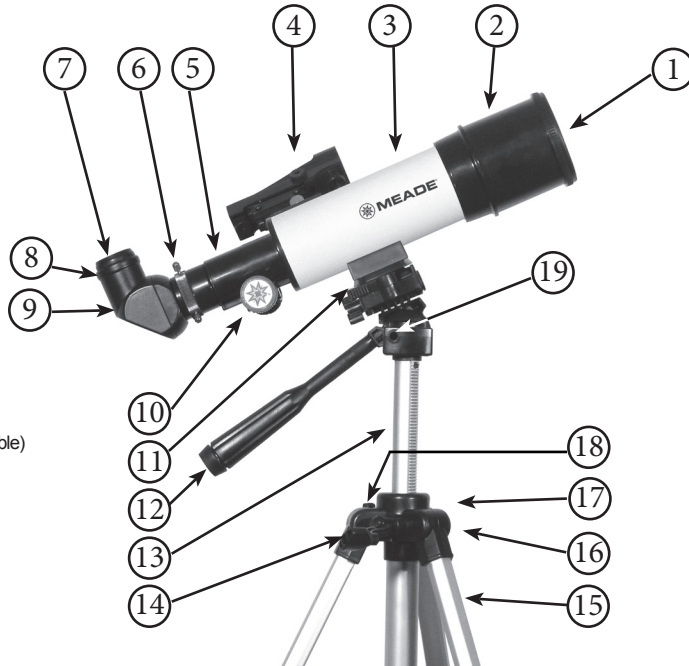

Looking at or near the Sun will cause irreversible damage to your eye. Do not point this telescope at or near the Sun. Do not look through the telescope as it is moving.

Note: Number in brackets, e.g., (3), refer to Fig. 1A, 1B, and 1C unless noted otherwise.

SETTING UP THE TRIPOD

1. Remove the tripod from the backpack.
2. Spread out the tripod legs until the leg struts(#20) are fully extended.
3. Turn the leg strut lock(#22)

Fig. 2



clockwise to secure the leg struts in place. This will prevent the tripod legs from collapsing inward causing instability. Be sure to set the tripod up on stable ground.

4. Adjust the tripod to the proper viewing height by unlock the tripod leg locks(#20) and slide out each tripod leg. Relock each leg lock(#20) to secure the leg in place.

5. Adjust each leg so the tripod head(#16) is in the level position. If needed, use the integrated bubble level(#18) located at the top of the tripod leg.

Fig. 3



ATTACHING THE SCOPE TO THE TRIPOD

1. Press the quick mount latch (#23) forward, as far as it will go, and hold it open.
2. Lift to remove the mounting shoe out of the tripod base, then let go of the latch.

Fig. 4

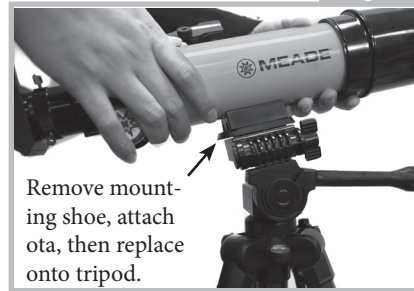

3. On the bottom of the mounting shoe, lift the wing-nut knob so that it stands straight out.
4. Thread the mounting shoe bolt into the bottom of the optical tube using the wing-nut knob to turn the bolt. Tighten to a firm feel.
5. Reopen the quick mount latch and slide the quick mount plate (with optical tube attached)



Looking at or near the Sun will cause irreversible damage to your eye. Do not point this telescope at or near the Sun. Do not look through the telescope as it is moving.

into tripod. The optical tube should point away from the panhandle.

6. Let go of the latch. If the latch does not close, reorient the plate until the plate lies flat within the tripod base.

ATTACHING THE ACCESSORIES

The Adventure scope is almost fully setup. Follow the below steps to attach the necessary accessories.

1. Remove the focuser dust cover.

2. **INSERT THE DIAGONAL** by loosening the thumbscrew at the focuser opening and insert the 90 degree erect-image diagonal. Tighten the thumbscrew to a firm feel.

3. **INSERT THE EYEPIECE** by loosening the thumbscrew at the erect-image diagonal opening. Insert the 18mm eyepiece. Re-tighten the thumbscrew to a firm feel.

4. **ATTACH THE RED DOT VIEWFINDER.** Locate the two thumbscrews on top of the optical tube near the rear of the telescope. Remove the two thumbscrews and set aside. Next place the red dot viewfinder over the thumbscrews so the viewing screen faces the front of the telescope. Replace the two thumbscrews and tighten to a firm feel.

USING THE TELESCOPE CONTROLS

- **Focus Knob:** Look into the eyepiece and rotate the focus knob in either direction to focus on an object.

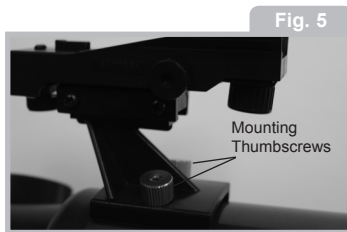

- **Zoom:** To zoom in or out on an object; use the different supplied eyepieces. You may

need to refocus the telescope every time you change eyepieces.

- **Moving the tube up and down:** Rotate the pan lever counterclockwise to unlock and move the tube up and down. Rotate the pan lever clockwise to lock the tube into place.

- **Moving the tube left and right:** Rotate the azimuth knob counterclockwise to unlock and move the tube left and right. Rotate the azimuth knob clockwise to lock the tube into place.

- **Indoor viewing vs. outdoor viewing:** Although you may casually observe through an open or closed window, the best observing is always done outdoors. Temperature differences between inside and outside air, and the low optical quality of window glass can blur images through the Adventure scope.



Looking at or near the **Sun** will cause **irreversible** damage to your eye. Do not point this telescope at or near the Sun. Do not look through the telescope as it is moving.

USING THE RED DOT FINDER

The red dot finder is a low-power sighting device that, once aligned, will allow you to point the telescope with greater precision. To work properly, the red dot finder must first be aligned to the telescope's main optical tube.

To align the viewfinder, follow these steps:

1. Remove the lens cap from the scope. Place the 18mm eyepiece in

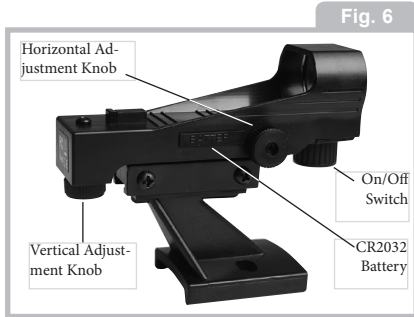

the erect-image diagonal and point the optical tube assembly at some well-defined, distant land object (e.g. the top of a distant telephone pole). It is recommended that you choose an object that is as distant as possible, so that the red dot finder alignment will be accurate enough to point the telescope at planets and stars during astronomical observations.

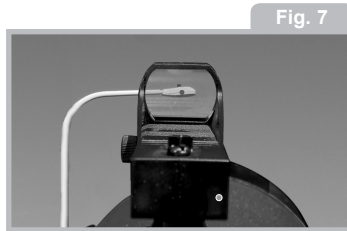

2. Use the two adjustment knobs located on the back of the scope and at the front so that the red dot can move up/down/left/right. Look through the finder and make the adjustments, so the red dot is precisely centered on the same object already centered in the telescope's 18mm eyepiece.

3. Objects located in the viewfinder will now be centered in the telescope eyepiece.

LOOKING THROUGH THE EYEPIECE

Once you have the object lined up in the viewfinder, look through the optical tube's eyepiece. If you have aligned your viewfinder, and adjusted the telescope focus, you will see the object in your 18mm eyepiece.

WHAT TO LOOK AT?

Terrestrial Observation

When viewing land objects, you will be observing through heat waves on the earth surface. You may have noticed these heat waves while driving down a highway during the summer. Heat waves cause a loss of image quality. Here are some quick tips to get the most out of your new telescope.

Always use the red dot finder and 18mm



Looking at or near the Sun will cause irreversible damage to your eye. Do not point this telescope at or near the Sun. Do not look through the telescope as it is moving.

eyepiece to locate objects. The 18mm eyepiece has a larger field of view with less magnification which makes it ideal for use when finding targets to observe. Once the target is located, you can switch to the 6mm eyepiece to zoom in.

If heat waves interfere with your viewing, try focusing at low magnification to see a steadier, higher-quality image.

Observe in early morning hours, before the earth has built up too much internal heat.

Observe during the daytime. Try out your telescope during the daytime at first. It is easier to learn how it operates and how to observe when it is light.

Pick out an easy object to observe first to help you become familiar with the telescope. A distant mountain, a large tree, a lighthouse or skyscraper make excellent targets. Point

the optical tube so it lines up with your object.

Celestial Observation

Observe the Moon:

When you feel comfortable with the viewfinder, the eyepieces, the locks and the adjustment controls, you will be ready to try out the telescope at night. The Moon is the best object to observe the first time you go out at night. Pick a night when the Moon is a crescent. No shadows are seen during a full Moon, making it appear flat and uninteresting.

Look for different features on the Moon. The most obvious features are craters. In fact you can see craters within craters. Some craters have bright lines about them. These are called rays and are the result of material thrown out of the crater when it was struck by a colliding object. The dark areas on the Moon are called Maria and are composed of lava from the period when the Moon still had volcanic activity. You can also see mountain

ranges and fault lines on the Moon.

Observe the Solar System:

After observing the Moon, you are ready to step up to the next level of observation, the planets. There are four planets that you can easily observe in your telescope: Venus, Mars, Jupiter and Saturn.

Eight planets (maybe more!) travel in a fairly circular pattern around our Sun. Any system of planets orbiting one or more stars is called a solar system. Our Sun, by the way, is a single, yellow dwarf star. It is average as far as stars go and is a middle aged star.

Beyond the planets are clouds of comets, icy planetoids and other debris left over from the birth of our sun. Recently astronomers have found large objects in this area and they may increase the number of planets in our solar system.



Looking at or near the Sun will cause irreversible damage to your eye. Do not point this telescope at or near the Sun. Do not look through the telescope as it is moving.

The four planets closest to the Sun are rocky and are called the inner planets. Mercury, Venus, Earth and Mars comprise the inner planets. Venus and Mars can be easily seen in your telescope.

Venus is seen before dawn or after sunset, because it is close to the Sun. You can observe Venus going through crescent phases. But you cannot see any surface detail on Venus because it has a very thick atmosphere of gas.

Meade Factoid

Jupiter's four brightest moons are easily visible in a telescope. When Galileo Galilei first observed them rotating around Jupiter in 1610, he saw proof that the earth wasn't the center of everything in the universe, as many then supposed.

When Mars is close to the Earth, you can see some details on Mars, and sometimes even Mars' polar caps. But quite often, Mars is further away and just appears as a red dot with some dark lines crisscrossing it.

Jupiter, Saturn, Uranus and Neptune comprise the outer planets. These planets are made mostly of gases and are sometimes called gas giants. If they had grown much bigger, they may have become stars.

Jupiter is quite interesting to observe. You can see bands across the face of Jupiter. The more time you spend observing these bands, the more detail you will be able to see.

One of the most fascinating sights of Jupiter are its moons. The four largest moons are called the Galilean moons, after the astronomer Galileo, who observed them for the first time. If you've never watched the Galilean moons in your telescope before, you're missing a real treat! Each night, the

Meade Factoid

The Sun is gigantic. It would take 109 earths side-by-side to make up the diameter of the sun, and 1.3 million Earth's to fill its volume. Yet, due to distance, the Sun looks exactly the same size as the moon in our sky.

moons appear in different positions around the Jovian sky. This is sometimes called the Galilean dance. On any given night, you might be able to see the shadow of a moon on the face of Jupiter, see one moon eclipse another or even see a moon emerge from behind Jupiter's giant disk. Drawing the positions of the moons each night is an excellent exercise for novice astronomers.

Any small telescope can see the four Galilean moons of Jupiter, plus a few others, but how many moons does Jupiter actually have? No one knows for sure! Nor are we sure how



Looking at or near the Sun will cause **irreversible** damage to your eye. Do not point this telescope at or near the Sun. Do not look through the telescope as it is moving.

many Saturn has either. At last count, Jupiter had over 60 moons, and held a small lead over Saturn. Most of these moons are very small and can only be seen with very large telescopes.

Probably the most memorable sight you will see in your telescope is Saturn. Although you may not see many features on the surface of Saturn, its ring structure will steal your breath away. You will probably be able to see a black opening in the rings, known as the Cassini band.

Fig. 8

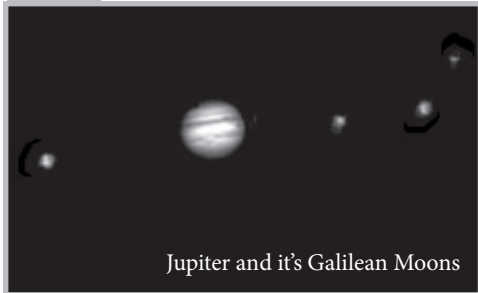

Jupiter and its Galilean Moons

Saturn is not the only planet that has rings, but it is the only set of rings that can be seen with a small telescope. Jupiter's rings cannot be seen from Earth at all—the Voyager spacecraft discovered the ring after it passed Jupiter and looked back at it. It turns out, only with the sunlight shining through them, can the rings be seen. Uranus and Neptune also have faint rings.

Observing beyond the Solar System:

Once you have observed our own system of planets, it's time to really travel far from home and look at stars and other objects.

You can observe thousands of stars with your telescope. At first, you may think stars are just pinpoints of light and aren't very interesting. But look again. There is much information that is revealed in stars.

The first thing you will notice is that not all stars are the same colors. See if you can

find blue, orange, yellow, white and red stars.

The color of stars sometimes can tell you about the age of a star and the temperature that they burn at.

Other stars to look for are multiple stars. Very often, you can find double (or binary) stars, stars that are very close together. These stars orbit each other. What do you notice about these stars? Are they different colors?

Meade Factoid

Saturn's rings of ice, dust and gas are huge and small at the same time. The main rings are so large they could almost reach from the earth to the moon. But they are only about a half of a mile (just a few city blocks) wide.



Does one seem brighter than the other?

Almost all the stars you can see in the sky are part of our galaxy. A galaxy is a large grouping of stars, containing millions or even billions of stars. Some galaxies form a spiral (like our galaxy, the Milky Way) and other galaxies look more like a large football and are called elliptical galaxies. There are many galaxies that are irregularly shaped and are thought to have been pulled apart because they passed too close to—or even through—a larger galaxy.

Meade Factoid

Just below the constellation Orion's famous belt of three stars (in the middle of his sword), is The Great Orion Nebula. This wonderful telescope target is really a cosmic star factory where a glowing gas cloud surrounds hot young stars.

You may be able to see the Andromeda galaxy and several others in your telescope. They will appear as small, fuzzy clouds. Only very large telescope will reveal spiral or elliptical details.

You will also be able to see some nebulas with your scope. Nebula means cloud. Most nebulas are clouds of gas. The two easiest to see in the Northern Hemisphere are the Orion nebula during the winter and the Lagoon nebula during the summer. These are large clouds of gas in which new stars are being born. Some nebulas are the remains of stars exploding. These explosions are called supernovas.

When you become an advanced observer you can look for other types of objects such as asteroids, planetary nebula and globular clusters. And if you're lucky, every so often a bright comet appears in the sky, presenting an unforgettable sight.

SOME OBSERVING TIPS

Eyepieces: Always begin your observations using the 12mm lower-power eyepiece. The 12mm eyepiece delivers a bright, wide field of view and is the best to use for most viewing conditions. Use the higher-power 6mm eyepiece to view details when observing the Moon and planets. If the image become fuzzy, switch back down to a lower power. Changing eyepieces changes the power or magnification of your telescope.

Objects move in the eyepiece: If you are observing an astronomical object (the Moon, a planet, star, etc.) you will notice that the object will begin to move slowly through the telescopic field of view. This movement is caused by the rotation of the Earth and makes an object move through the telescope's field of view. To keep astronomical objects centered in the field, simply move the telescope on one or both of its axes vertically and/or horizontally as needed. At higher powers, astronomical



Looking at or near the Sun will cause **irreversible** damage to your eye. Do not point this telescope at or near the Sun. Do not look through the telescope as it is moving.

objects will seem to move through the field of view of the eyepiece more rapidly.

Place the object to be viewed at the edge of the field and, without touching the telescope, watch it drift through the field to the other side before repositioning the telescope so that the object to be viewed is again placed at the edge of the field, ready to be further observed.

Vibrations: Avoid touching the eyepiece while observing through the telescope. Vibrations resulting from such contact will cause the image to move. Avoid observing sites where vibrations cause image movement (for example, near railroad tracks). Viewing from the upper floors of a building may also cause image movement.

Let your eyes “dark-adapt”: Allow five or ten minutes for your eyes to become “dark adapted” before observing. Use a red filtered flashlight to protect your night vision

when reading star maps, or inspecting the telescope. Do not use a regular flashlight or turn on other lights when observing with a group of other astronomers. You can make your own red filtered flashlight by taping red cellophane over a flashlight lens.

Viewing through windows: Avoid setting up the telescope inside a room and observing through an opened or closed window pane. Images may appear blurred or distorted due to temperature differences between inside and outside air. Also, it is a good idea to allow

TOO MUCH POWER?

Can you ever have too much power? If the type of power you're referring to is eyepiece magnification, yes you can! The most common mistake of the beginning observer is to “overpower” a telescope by using high magnifications which the telescope's aperture and atmospheric conditions cannot reasonably support. Keep in mind that a smaller, but bright and well-resolved image is far superior to one that is larger, but dim and poorly resolved. Powers above 400x should be employed only under the steadiest atmospheric conditions.

your telescope to reach the ambient (surrounding) outside temperature before starting an observing session.

When to observe: Planets and other objects viewed low on the horizon often lack sharpness the same object, when observed higher in the sky, will appear sharper and have greater contrast. Try reducing power (change your eyepiece) if your image is fuzzy or shimmers. Keep in mind that a bright, clear, but smaller image is more interesting than a larger, dimmer, fuzzy one. Using too high a power eyepiece is one of the most common mistakes made by new astronomers.

Surf the Web and visit your local library:

We recommend to go to your library or check out the internet for more information about astronomy. Learn about the basics: light years, orbits, star colors, how stars and planets are formed, red shift, the big bang, the different kinds of nebula, what are comets, asteroids and meteors and what is



Looking at or near the Sun will cause irreversible damage to your eye. Do not point this telescope at or near the Sun. Do not look through the telescope as it is moving.

a black hole. The more you learn about astronomy, the more fun, and the more rewarding your telescope will become.

TAKING CARE OF YOUR TELESCOPE

Your telescope is a precision optical instrument designed for a lifetime of rewarding viewing. It will rarely, if ever, require factory servicing or maintenance. Follow these guidelines to keep your telescope in the best condition:

- Avoid cleaning the telescope's lenses. A little dust on the front surface of the telescope's correcting lens will not cause loss of image quality.
- When absolutely necessary, dust on the front lens should be removed with very gentle strokes of a camel hair brush or blown off with an ear syringe (available at most pharmacies).
- Fingerprints and organic materials on the front lens may be removed with a solution of 3 parts distilled water to 1 part isopropyl alcohol. You may also add 1 drop of biodegradable dishwashing soap per pint of solution. Use soft, white facial tissues and make short, gentle strokes. Change tissues often.

STAR CHARTS

Star charts and planispheres are useful for a variety of reasons. In particular, they are a great aid in planning a night of celestial viewing.

A wide variety of star charts are available in books, in magazines, on the internet and on CD Roms. Meade offers AutoStar Suite™ software. Contact your local Meade dealer or Meade's Customer Service department for more information.

Astronomy and Sky and Telescope magazines print star charts each month for up-to-the-minute maps of the heavens.

THE MEADE 4M COMMUNITY

You haven't just bought a telescope, you have embarked on an astronomy adventure that never ends. Share the journey with others by accepting your free membership in the 4M community of astronomers.

Go to www.Meade4M.com to activate your membership today.



Looking at or near the Sun will cause **irreversible** damage to your eye. Do not point this telescope at or near the Sun. Do not look through the telescope as it is moving.

SPECIFICATIONS

60mm AdventureScope

Optical design.....Refractor
Optical focal length..... 360mm
Objective Lens Diameter.....60mm (2.36")
Focal ratio.....f/6
Mount.....Alt/Azimuth

80mm AdventureScope

Optical design.....Refractor
Optical focal length..... 400mm
Objective Lens Diameter.....80mm (3.15")
Focal ratio.....f/5
Mount.....Alt/Azimuth

SURF THE WEB

- The Meade 4M Community:
<http://www.meade4m.com>
- Sky & Telescope:
<http://www.skyandtelescope.com>
- Astronomy:
<http://www.astronomy.com>
- Astronomy Picture of the Day:
<http://antwrp.gsfc.nasa.gov/apod>
- Photographic Atlas of the Moon:
http://www.lpi.ursa.edu/research/lunar_orbiter
- Hubble Space Telescope Public Pictures:
<http://oposite.stsci.edu/pubinfo/pictures.html>

ASTRONOMY RESOURCES

- The Meade 4M Community
27 Hubble, Irvine, CA 92618
- Astronomical League
Executive Secretary
5675 Real del Norte, Las Cruces, NM 88012
- The Astronomical Society of the Pacific
390 Ashton Ave., San Francisco, CA 94112
- The Planetary Society
65 North Catalina Ave, Pasadena, CA 91106
- International Dark-Sky Association, Inc.
3225 N. First Avenue, Tucson, AZ 85719-2103



Looking at or near the **Sun** will cause **irreversible** damage to your eye. Do not point this telescope at or near the Sun. Do not look through the telescope as it is moving.

CHANGING THE VIEWFINDER BATTERY

If the viewfinder red dot does not illuminate, verify the viewfinder is on by rotating the knob below the viewfinder lens clockwise. If the red dot does not illuminate, the battery may need replacing.

To replace the battery, press the left side of the viewfinder housing labeled “push”. The battery compartment will slide out on the right side of the viewfinder (see Fig. 15). Replace the battery with a Lithium CR2032 battery with the positive side up. Then push the battery compartment back into the viewfinder and power on.



OPTIONAL ACCESSORIES

Additional Eyepieces (1.25" barrel diameter only): For higher or lower viewing magnifications, Meade's Series 4000 Super Plössl eyepieces, available in a wide variety of sizes, provide a high level of image resolution and color correction at an economical price. Contact your Meade Dealer or see the Meade catalog for more information. Visit us on the web at www.meade.com.

JOIN AN ASTRONOMY CLUB, ATTEND A STAR PARTY

One of the best ways to increase your knowledge of astronomy is to join an astronomy club. Check your local newspaper, school, library, or telescope dealer/store to find out if there's a club in your area.

Many groups also hold regularly scheduled Star Parties at which you can check out and observe with many different telescopes and other pieces of astronomical equipment. Magazines such as *Sky and Telescope* and *Astronomy* print schedules for many popular Star Parties around the United States and Canada.



Looking at or near the Sun will cause **irreversible** damage to your eye. Do not point this telescope at or near the Sun. Do not look through the telescope as it is moving.

MEADE CUSTOMER SERVICE

If you have a question concerning your telescope, call Meade Instruments Customer Service Department at (800) 626-3233.

Customer Service hours are 7:00AM to 4:00PM, Pacific Time, Monday through Friday. Write or call the Meade Customer Service Department first, before returning the telescope to the factory, giving full particulars as to the nature of the problem, as well as your name, address, and daytime telephone number. The great majority of servicing issues can be resolved by telephone, avoiding return of the telescope to the factory.

MEADE LIMITED WARRANTY

Every Meade telescope, spotting scope, and telescope accessory is warranted by Meade Instruments Corp ("Meade") to be free of defects in materials and workman-ship for a period of ONE YEAR from the date of original purchase in the U.S.A. Meade will repair or replace a product, or part thereof,

found by Meade to be defective, provided the defective part is returned to Meade, freight-prepaid, with proof of purchase. This warranty applies to the original purchaser only and is non-transferable. Meade products purchased outside North America are not included in this warranty, but are covered under separate warranties issued by Meade international distributors.

RGA Number Required: Prior to the return of any product or part, a Return Goods Authorization (RGA) number must be obtained from Meade by writing, or by calling (800) 626-3233. Each returned part or product must include a written statement detailing the nature of the claimed defect, as well as the owner's name, address, and phone number. This warranty is not valid in cases where the product has been abused or mishandled, where unauthorized repairs have been attempted or performed, or where depreciation of the product is due to normal wear and tear. Meade specifically disclaims special, indirect, or consequential

damages or lost profit which may result from a breach of this warranty. Any implied warranties which cannot be disclaimed are hereby limited to a term of one year from the date of original retail purchase. This warranty gives you specific rights. You may have other rights which vary from state to state. Meade reserves the right to change product specifications or to discontinue products without notice. This warranty supersedes all previous Meade product warranties.



Looking at or near the Sun will cause **irreversible** damage to your eye. Do not point this telescope at or near the Sun. Do not look through the telescope as it is moving.

RECYCLING INFORMATION (EU Countries only)

Correct Disposal of this Product (Waste Electrical & Electronic Equipment)

This marking shown on the product or its literature indicates that it must not be disposed of in unsorted municipal waste at the end of its working life. To prevent possible harm to the environment or human health from uncontrolled waste disposal, please separate this from other types of wastes and recycle it as required by law. Household users should contact either the retailer where they purchased this product, or their local government office, for details of where and how they can take this item for environmentally safe recycling. Business users should contact their supplier and check the terms and conditions of the purchase contract. This product should not be mixed with other commercial wastes for disposal.

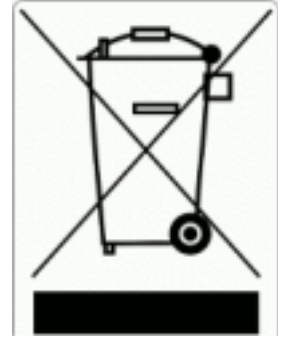

OBSERVATION LOG

OBSERVER: _____

OBJECT NAME: _____

DATE & TIME OBSERVED: _____

CONSTELLATION: _____

EYEPIECE SIZE: _____

SEEING CONDITIONS: EXCELLENT GOOD POOR

NOTES: _____



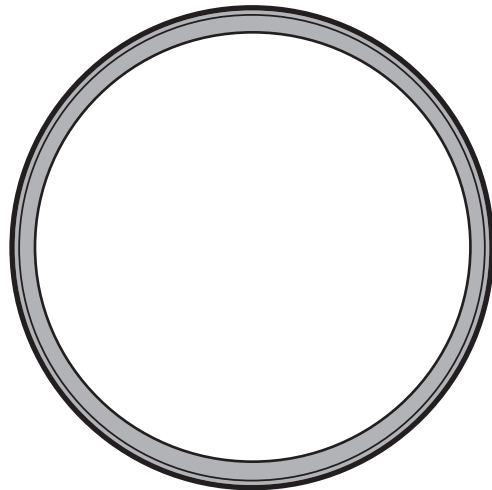

DRAWING OF IMAGE

OBSERVATION LOG

OBSERVER: _____

OBJECT NAME: _____

DATE & TIME OBSERVED: _____

CONSTELLATION: _____

EYEPIECE SIZE: _____

SEEING CONDITIONS: EXCELLENT GOOD POOR

NOTES: _____



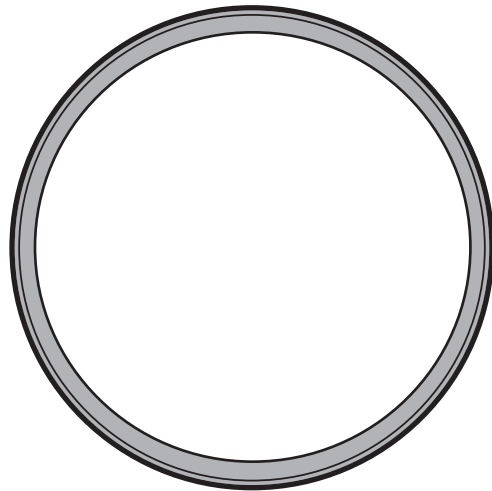

DRAWING OF IMAGE

OBSERVATION LOG

OBSERVER: _____

OBJECT NAME: _____

DATE & TIME OBSERVED: _____

CONSTELLATION: _____

EYEPIECE SIZE: _____

SEEING CONDITIONS: EXCELLENT GOOD POOR

NOTES: _____



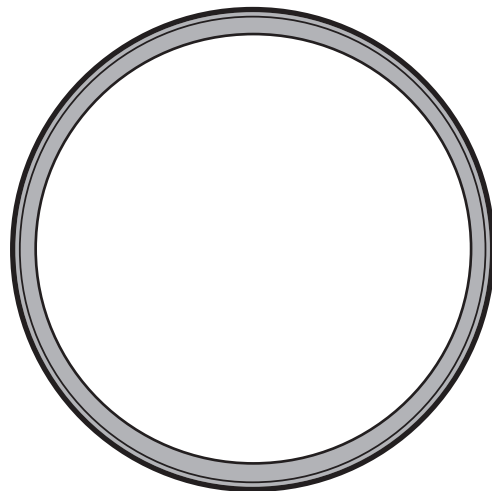
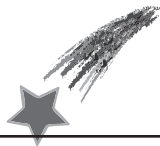

DRAWING OF IMAGE

1-800 626-3233

Meade Instruments Corp.
27 Hubble, Irvine,
California

926 18

www.meade.com

June 2016 v001