



→ **ECLIPSE** VIEW™ 60

→ **ECLIPSE** VIEW™ 76
Instruction Manual



MEADE®
INSTRUMENTS

Sun Warning

WARNING!

- o Always use the EclipseView Solar Filter when viewing at or near the Sun. When viewing a solar eclipse, always use this solar filter during ALL phases of the eclipse.
- o Before use always check both sides of the solar filter for damage. Do not use if scratches, pin-holes, or the filter is separated from its holder.
- o This item is not a toy and requires adult supervision.
- o Failure to use proper solar filtering can cause severe & permanent eye injury including blindness.
- o Do not attempt to clean or disinfect the filter material.

ALWAYS USE THE SUN FILTER WHEN VIEWING AT OR NEAR THE SUN.

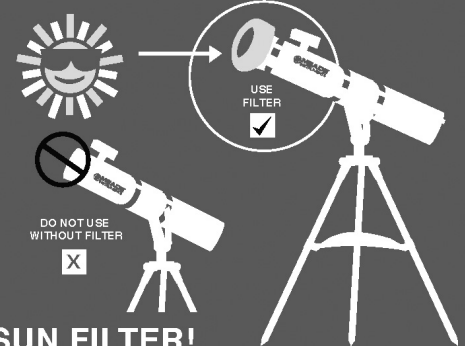

SUN FILTER!
WARNING
ADULT SUPERVISION REQUIRED

Solar Filter Safety Compliance Information:

- o Meets the requirements for ISO 12312-2:2015
- o CE certified which meets the transmission requirements of scale 12-16 of EN 169/1992.
- o Meets the transmission requirements of EN 1836:2005 & AS/NZS 1338.1:1992 for Eclipse filters. (Queensland Directive).



Always use the EclipseView Solar Filter when viewing at or near the Sun or irreversible eye damage may occur.

Quick Start - Viewing the Sun

In order to get started observing the Sun, you will need to do the following:

1) Read the Instructions!

- Viewing the Sun can be dangerous.
- Read the instructions carefully.

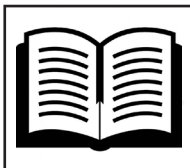

2) Setup the Tripod

- Expand the tripod legs.
- Adjust tripod leg height.



3) Attach the Accessory Tray

- **EclipseView 60:** Use the three wingnuts and thread into bottom side of tray.
- **EclipseView 76:** Thread tray into center nut between tripod legs.



4) Attach Optical tube to Mount

- Remove yellow ota mounting knobs.
- Insert Slow-Motion control rod into holder.
- Place Optical tube into mount.
- Reattach yellow ota mounting knobs.



5) Confirm Solar Filter is not damaged and properly installed!

- Viewing the Sun can be dangerous.
- Always confirm the filter is good before each use.



6) Attach Accessories

- **EclipseView60:** Attach 90° diagonal & 26mm eyepiece. Attach SunFinder.
- **EclipseView76:** Attach 26mm eyepiece. Attach SunFinder.



7) Use the SunFinder to locate the Sun

- Use the Sun's projection and place in center area of SunFinder.



8) Focus the telescope until image is sharp.

- Only view the Sun with the proper Meade solar filtering or permanent eye damage can occur!

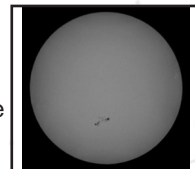

Always use the EclipseView Solar Filter when viewing at or near the Sun or irreversible eye damage may occur.

Quick Start - Viewing at Night

In order to get started observing nighttime objects, you will need to do the following:

1) Read the Instructions!

- Knowing how the telescope operates and what you will see is critical to enjoying the use of your telescope.



2) Setup the Tripod

- Expand the tripod legs.
- Adjust tripod leg height.



3) Attach the Accessory Tray

- **EclipseView 60:** Use the three wingnuts and thread into bottom side of tray.
- **EclipseView 76:** Thread tray into center nut between tripod legs.



4) Attach Optical tube(ota) to Mount

- Remove yellow ota mounting knobs.
- Insert Slow-motion control rod into holder.
- Place optical tube into mount arms.
- Reattach yellow ota mounting knobs.



5) Attach Accessories

- **EclipseView60:** Attach 90 ° diagonal & 26mm eyepiece. Attach Red-dot Finder.
- **EclipseView76:** Attach 26mm eyepiece. Attach Red-dot Finder.



6) Align the Red-dot Finder

- Find a distant object and center in the eyepiece. A distant land object is ideal for this and can be done in daytime.
- Adjust Red-dot finder controls to align red-dot over distant object.

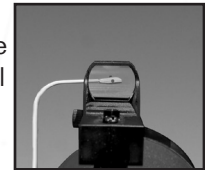

7) Point the telescope at a bright object

- The Moon an ideal target for this.

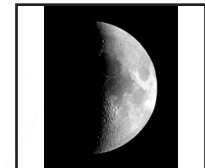

8) Focus the telescope until image is sharp.

- Enjoy the view!

3  Always use the EclipseView Solar Filter when viewing at or near the Sun or irreversible eye damage may occur.

Table Of Contents

Sun Warning.....	1	Quick Start – Viewing at Night.....	28
Quick Start – Viewing the Sun.....	2	Attaching The Accessories.....	29
Quick Start – Viewing at Night.....	3	Installing The Red-Dot Finder.....	29
Introduction.....	5	Inserting The Eyepiece.....	30
Telescope Features – 60mm.....	6	Aligning The Red-dot Viewfinder.....	31
Telescope Features – 76mm.....	7	Moving The Telescope.....	33
Specifications.....	8	How To Use Your Telescope.....	34
About Your Telescope.....	9	Observing at Night.....	35
Assembling The Telescope.....	10	Resources.....	39
Attaching The Optical Tube Assembly(OTA).....	11	Tip and Tricks.....	41
Remove The Dust Covers.....	12	Calculating Magnification.....	42
Insert The Erect-Image Prism (60mm Models).....	12	Collimation.....	43
Insert The Eyepiece.....	13	Viewfinder Battery Replacement.....	49
Attaching the Finder.....	14	Care and Maintenance.....	50
DayTime Use of the Telescope.....	16	Accessories.....	51
Quick Start – Viewing the Sun.....	17	Recycling.....	52
Using the Solar Filter.....	18	Customer Service and Warranty.....	53
Installing the Solar Filter.....	20		
Installing the SunFinder.....	20		
Using the SunFinder.....	21		
Observing the Sun.....	22		
How to Observe a Solar Eclipse.....	24		
Solar Filter Maintenance.....	26		
Solar Filter Safety Compliance.....	26		
NightTime Use of the Telescope.....	27		



Introduction

Congratulations on getting a Meade EclipseView Telescope! Now you can setup and share the stargazing & solar viewing experience in seconds. Whether you are camping in the outdoors or relaxing in your backyard, grab your EclipseView Telescope and take it wherever life takes you. Your telescope is already partially assembled for you at our factory, so you only have to connect the optical tube to the mount, attach the accessories to start viewing the sun, galaxies, planets, stars and more!

Each telescope contains the following parts:

EclipseView 60



- Optical Tube
- Alt-Az Mount
- Tripod
- Solar Filter
- Two Eyepieces
- Erect-Image Prism
- SunFinder
- Red-dot Finder
- Software DVD

EclipseView 76



- Optical Tube
- Alt-Az Mount
- Tripod
- Solar Filter
- Two Eyepieces
- SunFinder
- Red-dot Finder
- Software DVD

Telescope Features EclipseView 60

FIGURE 1A

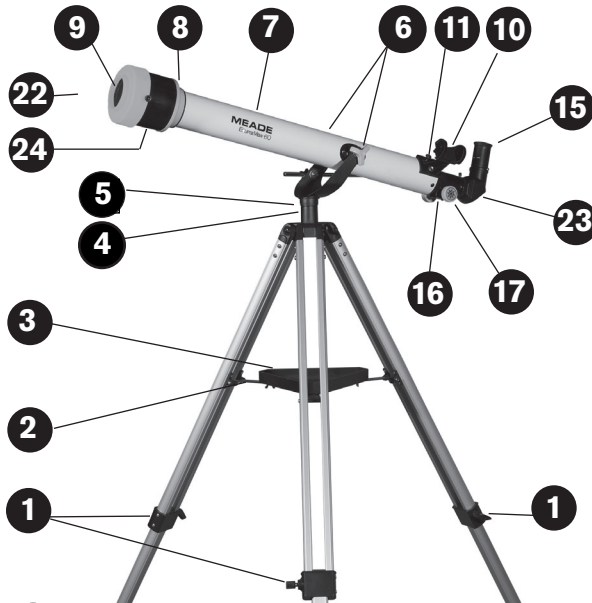

1. Tripod leg lock
2. Leg brace supports
3. Accessory tray
4. Alt-Az mount
5. Azimuth lock knob
6. Altitude lock knobs
7. Optical tube assembly (OTA)
8. Objective lens
9. Solar Filter
10. SunFinder
11. Finder mounting knobs
12. Red-dot finder
13. Red-dot finder On/Off switch
14. Red-dot finder adjustments
15. Eyepiece
16. Focuser
17. Focus knobs
18. Focuser thumbscrews
19. Slow-motion control rod
20. Slow-motion lock knob
21. OTA mounting knobs(2)
22. Front dust cap (not visible)
23. Erect-image prism
24. Dew shield

Image A

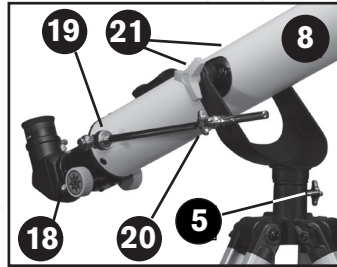

Image B

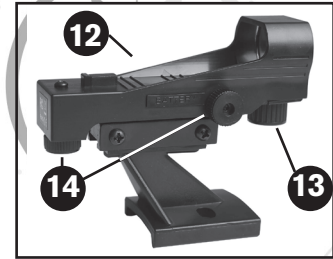
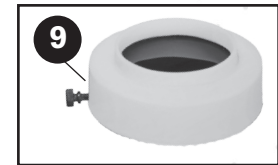

Image C



Image D



Always use the EclipseView Solar Filter when viewing at or near the Sun or irreversible eye damage may occur.

Telescope Features EclipseView 76

FIGURE 1B



Image A



Image B

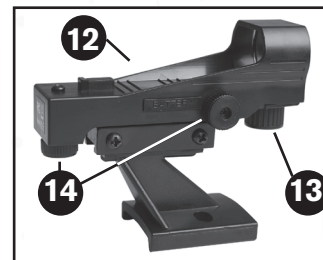

- | | |
|--------------------------------|--|
| 1. Tripod leg lock | 16. Focuser |
| 2. Leg brace supports | 17. Focus knobs |
| 3. Accessory tray | 18. Focuser thumbscrews |
| 4. Alt-Az mount | 19. Slow-motion control rod |
| 5. Azimuth motion lock knob | 20. Slow-motion lock knob |
| 6. Altitude lock knobs | 21. OTA mounting knobs(2) |
| 7. Optical tube assembly (OTA) | 22. Front dust cap (not visible) |
| 8. Primary Mirror | 23. Primary mirror adjustment screws |
| 9. Solar Filter | 24. Secondary mirror adjustment screws |
- *Required for viewing the Sun.
10. SunFinder
 11. Finder mounting knobs
 12. Red-dot finder
 13. Red-dot finder On/Off switch
 14. Red-dot finder adjustments
 15. Eyepiece

Image C



Image D

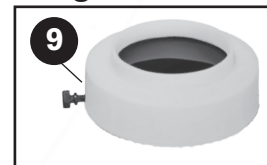

7  Always use the EclipseView Solar Filter when viewing at or near the Sun or irreversible eye damage may occur.

Specifications

EclipseView 60

Refractor

800mm

60mm (2.4 in.)

f/13.3

SunFinder for Daytime
Red-dot for Nighttime

Two 1.25" MA26mm, MA9mm

White-Light Filter
(Removable)

Included

EclipseView 76

Reflector

700mm

76mm (3 in.)

f/9.2

SunFinder for Daytime
Red-dot for Nighttime

Two 1.25" MA26mm, MA9mm

White-Light Filter
(Removable)

N/A

Optical tube design

Optical tube focal length

Lens/Mirror diameter

Focal ratio

Viewfinder

Eyepieces

Solar Filter

Erect-Image Prism

About The Telescope

The EclipseView Telescopes are Alt-Az mounted telescopes. The word “Alt-Az” comes from the way the telescope mount moves. This mount style allows you to move the telescope both up/down (altitude) and left/right (azimuth), or Altitude-Azimuth directions. Hence, it’s called an Alt-Az telescope for short. This is the simplest type of mount sold.

The EclipseView60 optical tubes are called refractors because they use lenses to refract, or bend, the incoming light to the focal point. The light at the focal point is then magnified by the eyepiece to provide a larger viewing image.

The EclipseView76 optical tubes are called reflectors because they use mirrors to focus incoming light. Inside the telescope, there are two mirrors: a primary and a secondary mirror. The primary mirror is the largest of the two and is located at the bottom of the tube. The secondary mirror is near the top of the tube. The large primary mirror collects light from the object you’re looking at and bounces it forward to the secondary mirror which redirects it out the side of the tube. The reflecting telescope must have the mirrored elements aligned, or collimated, in order to get good image quality.

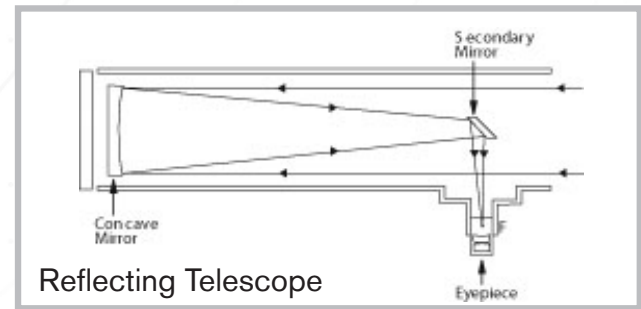
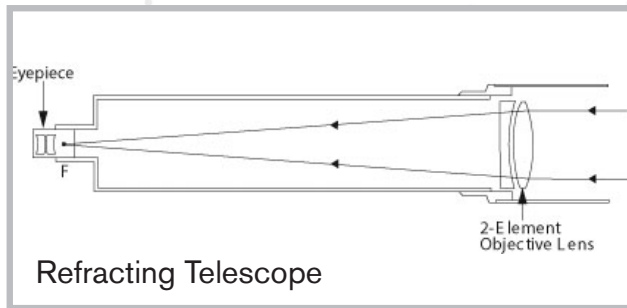

9  Always use the EclipseView Solar Filter when viewing at or near the Sun or irreversible eye damage may occur.

Assembling The Telescope

Tripod Assembly:

The tripod is the basic support for your telescope and comes pre-assembled from the factory; except for the accessory tray. In order to use the scope a small amount of assembly is required. Follow the below steps to assemble the telescope.

STEP 1: To setup the tripod, spread the legs out evenly and place on solid ground. Loosen the leg lock knobs and extend the inner legs to desired height. Do this for each leg until the top of the tripod is approximately level. Re-lock the leg lock knob.

STEP 2:

EclipseView 60 Models: Attach the accessory tray to the tripod by aligning the three mounting hole at each corner with the slotted holes on each leg brace. Use the included wing-nuts and thread into the tray from the bottom.

EclipseView 76 Models: Attach the accessory tray to the tripod by threading it into the center nut between the tripod legs.

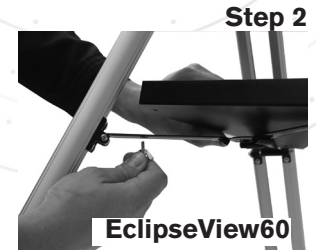
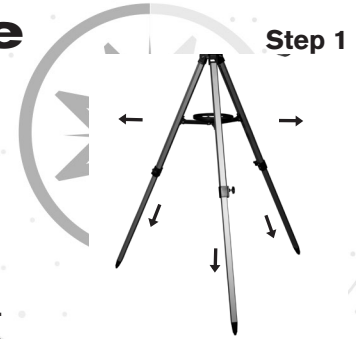

Attaching The Optical Tube Assembly (OTA):

The optical tube gathers distant light which is focused in the eyepiece.

STEP 1: Remove the two lock knobs from the optical tube mount.

STEP 2: Slide the Slow-motion control rod into the slow-motion control lock knob hole.

STEP 3: Place the optical tube between the forks of the mount, oriented as shown.

STEP 4: Thread a lock knobs through each of the holes in the forks of the mount and tighten to a firm feel.



Remove The Dust Covers:

The dust covers located at the front and rear of the telescope protect the telescope

STEP 1: Remove dust covers(6) at the front of the scope by pulling the cover away from the telescope. Set aside so you can re-install it after use.

STEP 2: Remove the dustcover from the focuser by pulling it out of the focuser drawtube. Set aside so you can re-install it after use.

Insert The Erect-Image Prism (EclipseView60 Models Only):

The 90° Erect-Image Prism reflects the light from the optical tube to a more comfortable viewing position. It also reorients (corrects) the image so the object appears right side up and left-right correct. This makes the EclipseView60 and ideal choice for both terrestrial viewing and night time observing.

STEP 1: To install, slide the diagonal prism into the focuser draw tube.

STEP 2: Tighten the draw tube thumbscrew to hold the diagonal prism securely.



Insert The Eyepiece:

STEP 1:

EclipseView60 Models: Slide the MA 26mm eyepiece into diagonal prism.

EclipseView76 Models: Slide the MA 26mm eyepiece directly into the focuser drawtube.

STEP 2:

EclipseView60 Models: Tighten the diagonal prism thumbscrew to hold the eyepiece securely.

EclipseView76 Models: Tighten the focuser drawtube thumbscrew to hold the eyepiece securely.

Step 1



Step 1



Attaching The Finder:

An eyepiece has a narrow field of view. A viewfinder, or finder, has a wider field of view, which makes it easier to locate objects.

The EclipseView telescopes comes with two different viewfinders. Each finder has a different use and should only be used as intended.

SunFinder: Use only when trying to locate the Sun. This SunFinder uses the Sun's bright light to project a small dot onto the finder's back plate. Center the projected white spot in the centering circle on the back plate. The Sun should then be in the field of view of a low power eyepiece such as the 26mm MA eyepiece. **Always use the included Solar Filter when looking at or near the Sun.**

Red-dot Finder: Use the Red-dot viewfinder only on the night time sky or daytime land objects. Never use it to look at or near the Sun as permanent eye damage can occur. This finder has a red dot projected onto a screen which makes it easier to line up more precisely with the target. To install the finders do the following:

STEP 1: Note the two thumbscrews threaded onto two bolts on the optical tube. Remove the thumbscrews from the tube.

STEP 2: Line up the two holes on the viewfinder bracket over the two bolts. Slide the bracket over the bolts.

STEP 3: Replace the thumbscrews onto the bolts and tighten to a firm feel.



Red-dot Finder



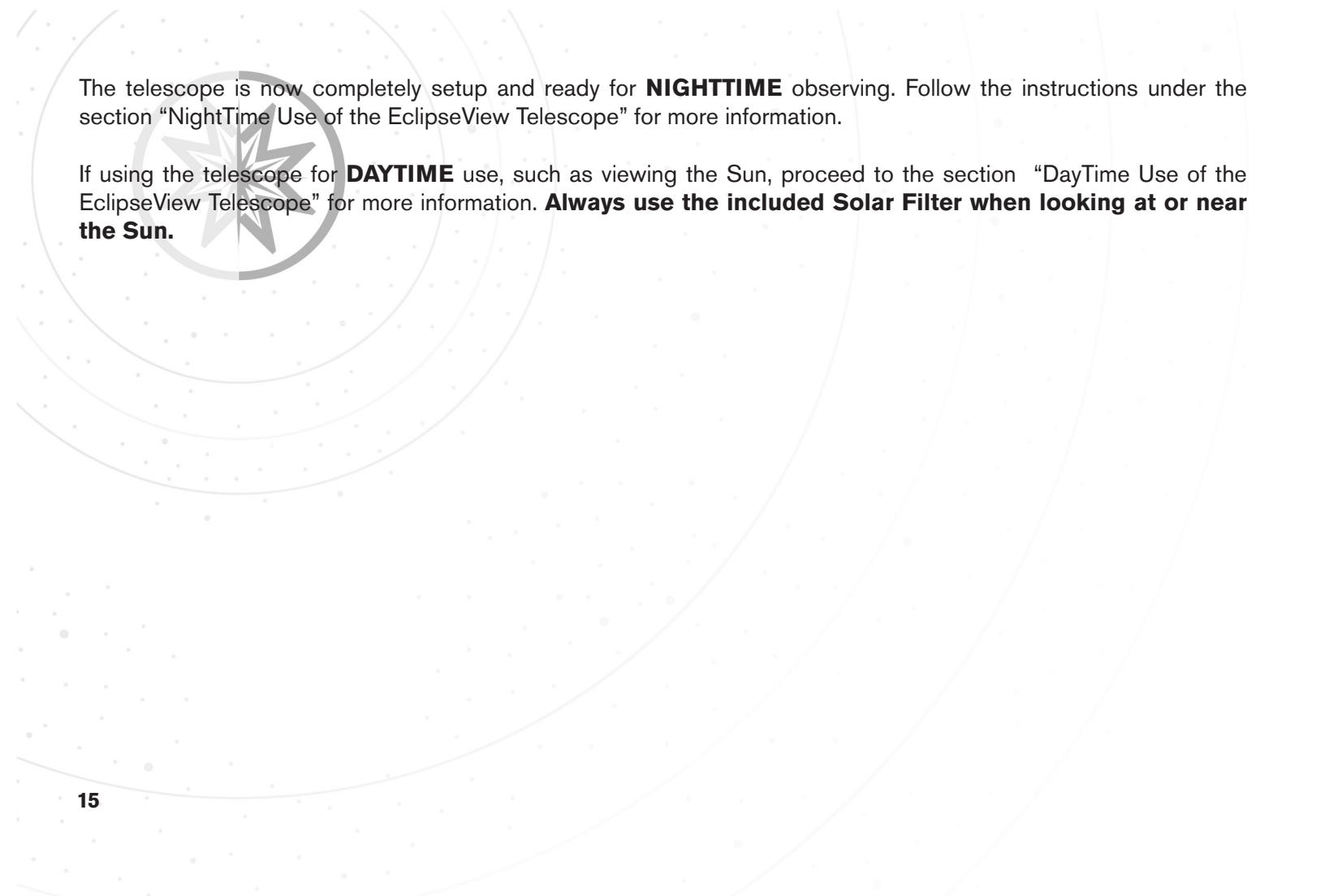

The telescope is now completely setup and ready for **NIGHTTIME** observing. Follow the instructions under the section “NightTime Use of the EclipseView Telescope” for more information.

If using the telescope for **DAYTIME** use, such as viewing the Sun, proceed to the section “DayTime Use of the EclipseView Telescope” for more information. **Always use the included Solar Filter when looking at or near the Sun.**

**DAY TIME USE
OF THE
ECLIPSEVIEW
TELESCOPE**



Quick Start - Viewing the Sun

In order to get started observing the Sun, you will need to do the following:

1) Read the Instructions!

- Viewing the Sun can be dangerous.
- Read the instructions carefully.



2) Setup the Tripod

- Expand the tripod legs.
- Adjust tripod leg height.



3) Attach the Accessory Tray

- **EclipseView 60:** Use the three wingnuts and thread into bottom side of tray.
- **EclipseView 76:** Thread tray into center nut between tripod legs.



4) Attach Optical tube to Mount

- Remove yellow ota mounting knobs.
- Insert Slow-Motion control rod into holder.
- Place Optical tube into mount.
- Reattach yellow ota mounting knobs.



5) Confirm Solar Filter is not damaged and properly installed!

- Viewing the Sun can be dangerous.
- Always confirm the filter is good before each use.



6) Attach Accessories

- **EclipseView60:** Attach 90° diagonal & 26mm eyepiece. Attach SunFinder.
- **EclipseView76:** Attach 26mm eyepiece. Attach SunFinder.



7) Use the SunFinder to locate the Sun

- Use the Sun's projection and place in center area of SunFinder.

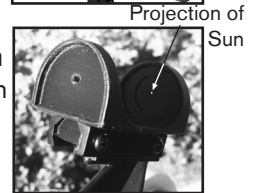

8) Focus the telescope until image is sharp.

- Only view the Sun with the proper Meade solar filtering or permanent eye damage can occur!

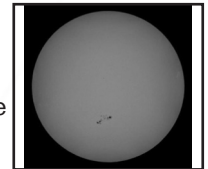

Using The Solar Filter

CAUTION: NEVER look through your telescope at or near the Sun until the solar filter is securely installed at the front of the telescope. Please read the following instructions fully and keep them in mind when observing the Sun. Always use caution when viewing at or near the Sun. Adult Supervision is required.

Inspecting the Solar Filter:

All filters are checked carefully before shipment. However, as the solar filter material is delicate, be sure to check for any damage prior to each use.

STEP 1: Before installing the solar filter, hold the solar filter up to the sky away from the Sun or use a standard 60 to 100 watt light bulb.

STEP 2: Examine the filter for any pin holes, scratches, tears, or signs the filter material has separated from its holder. If any damage is seen, do not use the solar filter. Replacement will be required.

Installing the Solar Filter: The solar filter is pre-installed at our factory to allow use right out of the box. However, if the solar filter is removed from the telescope make sure to reinstall the filter before looking at or near the Sun. To



Step 1.



install the filter, do the following.

STEP 1: Point the telescope upwards away from the Sun.

STEP 2: Carefully slide the filter fully over the front end of the telescope. Never force the filter onto the optical tube or damage can occur.

STEP 3: Tighten the thumb screw located on side the filter until firm. Do not overtighten the thumb screw.

STEP 4: The solar filter is now installed and ready to use on the Sun. Always use caution when viewing at or near the Sun.

STEP 5: When removing the solar filter, point the telescope away from the Sun first, then remove the filter. Removing the filter while the telescope is still pointed at the Sun is very dangerous and can cause serious damage to the telescope or anyone that may unknowingly attempt to look through the now unfiltered telescope.

Step 2.

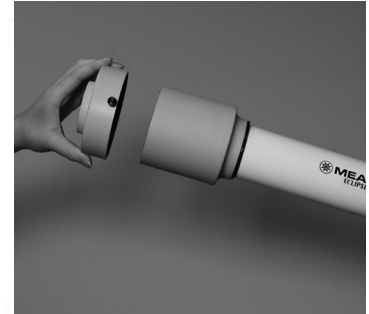

Step 3.



Installing the SunFinder:

The SunFinder is a pointing device that will allow you to easily locate the Sun. Follow the below instructions to install and use the SunFinder.

STEP 1: Remove the two viewfinder mounting thumb screws from the optical tube.

STEP 2: Place the SunFinder mounting bracket onto the threaded screws, with the SunFinder pin hole pointed forward towards the front of the telescope.

STEP 3: Use the two mounting thumb screws to secure the SunFinder bracket onto the optical tube. Tighten to a firm feel.



Using The SunFinder:

STEP 1: To use the SunFinder point the telescope toward the Sun. The small pinhole in the front of the SunFinder will act as a projector. As the telescope moves closer to the Sun, a projection of the Sun will be displayed on the back plate of the SunFinder.

STEP 2: Center the projection in the middle to the finder viewing circle.

STEP 3: We recommend using the lowest power eyepiece, such as the 26mm eyepiece to initially find the Sun. You can then center the sun in the eyepiece, then switch to higher power eyepieces if desired to zoom in on detail such as Sunspots.

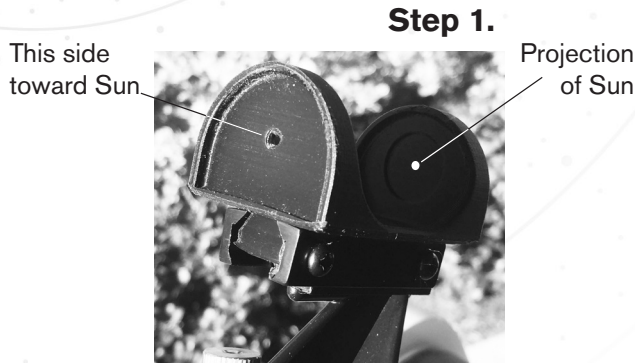

Observing The Sun:

What makes our Sun so enjoyable to observe is that it's an active star that's always changing. When viewing the Sun through the EclipseView solar filter, the Sun will show up as a yellow-orange disk with possible Sunspots on its surface.

Sunspots are temporary dark regions on the Sun where the surface temperature is cooler than the surrounding material. They are places where the Sun's ever-changing magnetic field prevents the hotter material from below from reaching the surface. Sunspots are continuously changing on a daily basis, sometimes even on an hourly basis and always occur in pairs just like the North & South Pole of a magnet. When viewing Sunspots you will notice they always have different shapes and sizes where no two Sunspots are the same.

Our Sun goes through an eleven year cycle where its surface activity increases dramatically. During increased surface activity, many Sunspots can be observed near the solar equator. As the solar activity increases, Sunspots typically will be seen closer to the Sun's north and south poles. During periods of low surface activity, the number of Sunspots will reduce drastically and often no Sunspots will be visible at all.

As the number of Sunspots are constantly changing, don't get discouraged if you don't see any Sunspots when observing the Sun. Check back again on another day, and look carefully on the solar surface. How many Sunspots do

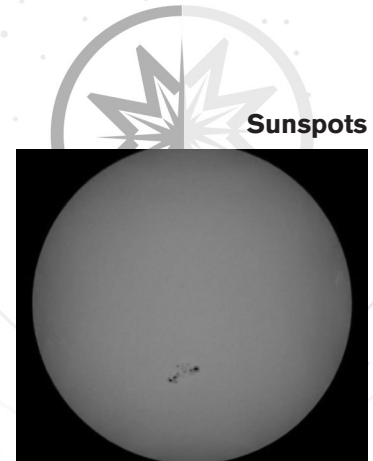

Planetary Transit

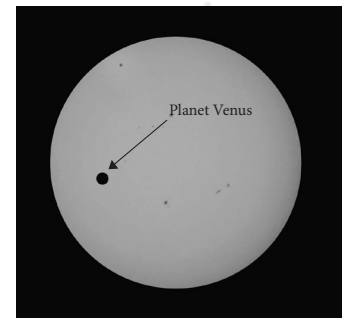

you see each day?

Planetary transits are another exciting feature to see when observing the Sun. Although this event happens infrequently, it occurs when the planet Mercury or Venus passes in front of the Sun. From your EclipseView telescope this would look like a small black dot travelling very slowly across the face of the Sun. These rare planetary transits are well known in advance and often mentioned on the local news days before they occur.

Solar Eclipses occur when the Moon, during its monthly trip around the Earth, passes between the Earth and the Sun. This causes the Moon's shadow to be cast onto a small part of the Earth. This shadow will have two distinct regions, the innermost and darkest region called the umbra and the outer brighter region called the penumbra. The dark umbra region is a very narrow region sometimes 60 - 100 miles wide. The penumbra region covers a much larger area and can be almost 4,000 miles wide.

There are three different types of solar Eclipses:

A **Partial Solar Eclipse** occurs when the Moon passes in front of the Sun and blocks only a portion of the Sun. This is the most common type of solar eclipse. The Sun will look like a bite has been taken out of it.

An **Annular Solar Eclipse** occurs when the Moon passes directly in front
23 of the Sun, but only blocks the central portion of the Sun. During this

Partial Solar Eclipse



Annular Solar Eclipse

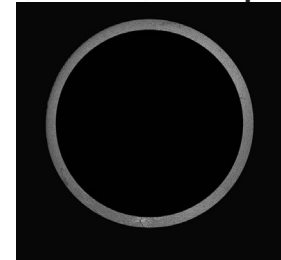

Total Solar Eclipse



type of eclipse, the Moon is a smaller apparent size than the Sun and cannot completely block the Sun. As a result, the Sun's entire edge, or annular region, is still visible around the Moon.

A **Total Solar Eclipse** occurs when the Moon passes directly in front of the Sun, blocking the entire solar disk. During this type of eclipse, the Moon and Sun overlap completely and observers located in the shadows darker umbra region will experience “totality”. During “totality”, or maximum blockage, the daytime sky can noticeably darken in a matter of minutes. This is the most prized of all solar eclipses and few people see this in their lifetime. The partial, annular, and total solar eclipses are events you don't want to miss!

How To Observe A Solar Eclipse:

CAUTION: NEVER look through your telescope at or near the Sun until the solar filter is securely installed at the front of the telescope. Please read the following instructions fully and keep them in mind before observing the Sun. Always use caution when viewing at or near the Sun. Adult Supervision is required.

To view the solar eclipse, make sure you have the front EclipseView solar filter installed. Never look at the Sun without the solar filter installed or severe damage to your eye can occur, including blindness.

The view through the EclipseView Solar filter should be comfortable, and not

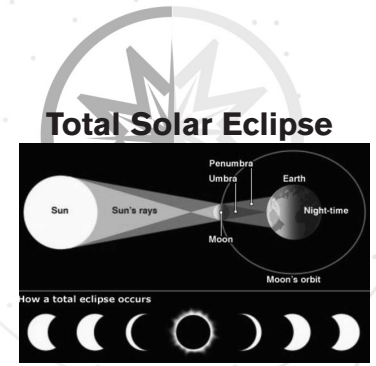

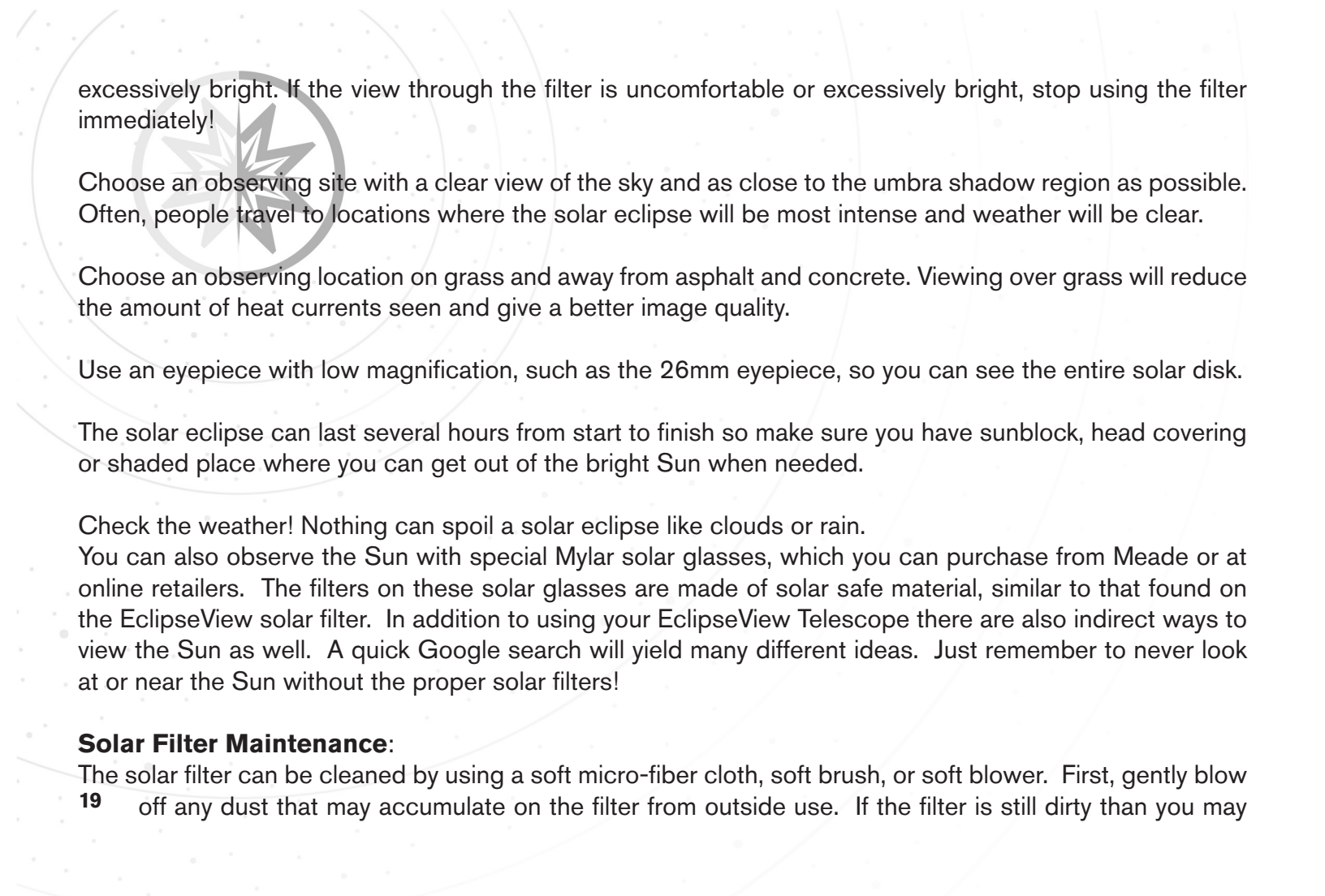

excessively bright. If the view through the filter is uncomfortable or excessively bright, stop using the filter immediately!

Choose an observing site with a clear view of the sky and as close to the umbra shadow region as possible. Often, people travel to locations where the solar eclipse will be most intense and weather will be clear.

Choose an observing location on grass and away from asphalt and concrete. Viewing over grass will reduce the amount of heat currents seen and give a better image quality.

Use an eyepiece with low magnification, such as the 26mm eyepiece, so you can see the entire solar disk.

The solar eclipse can last several hours from start to finish so make sure you have sunblock, head covering or shaded place where you can get out of the bright Sun when needed.

Check the weather! Nothing can spoil a solar eclipse like clouds or rain.

You can also observe the Sun with special Mylar solar glasses, which you can purchase from Meade or at online retailers. The filters on these solar glasses are made of solar safe material, similar to that found on the EclipseView solar filter. In addition to using your EclipseView Telescope there are also indirect ways to view the Sun as well. A quick Google search will yield many different ideas. Just remember to never look at or near the Sun without the proper solar filters!

Solar Filter Maintenance:

The solar filter can be cleaned by using a soft micro-fiber cloth, soft brush, or soft blower. First, gently blow off any dust that may accumulate on the filter from outside use. If the filter is still dirty than you may use a soft brush or micro-fiber cloth to remove the debris by gently wiping away the dust or debris. Do not clean with water or other liquids.

Please keep in mind that the solar filter film can be sensitive and the film can be scratched or damaged easily. The solar filter should be handled with care at all times to ensure safety when in use. This will also minimize accidental damage.

When the filter is not in use, store in a cool dry place.

Solar Filter Safety Compliance:

The EclipseView solar filter meets the following safety and compliance standards:

- Meets the requirements for ISO 12312-2:2015
- “CE” certified to the transmission requirements of scale 12-16 of EN 169/1992
- Meets the 2012 Transmission Requirements of EN 1836:2005 & AS/NZS 1338.1:1992 for Eclipse filters

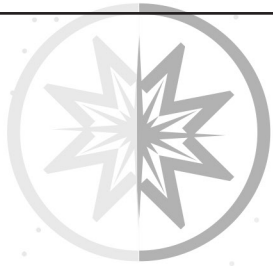

NIGHTTIME USE OF THE ECLIPSEVIEW TELESCOPE

Quick Start - Viewing at Night

In order to get started observing nighttime objects, you will need to do the following:

1) Read the Instructions!

- Knowing how the telescope operates and what you will see is critical to enjoying the use of your telescope.



2) Setup the Tripod

- Expand the tripod legs.
- Adjust tripod leg height.



3) Attach the Accessory Tray

- **EclipseView 60:** Use the three wingnuts and thread into bottom side of tray.
- **EclipseView 76:** Thread tray into center nut between tripod legs.



4) Attach Optical tube(ota) to Mount

- Remove yellow ota mounting knobs.
- Insert Slow-motion control rod into holder.
- Place optical tube into mount arms.
- Reattach yellow ota mounting knobs.



5) Attach Accessories

- **EclipseView60:** Attach 90 ° diagonal & 26mm eyepiece. Attach Red-dot Finder.
- **EclipseView76:** Attach 26mm eyepiece. Attach Red-dot Finder.



6) Align the Red-dot Finder

- Find a distant object and center in the eyepiece. A distant land object is ideal for this and can be done in daytime.
- Adjust Red-dot finder controls to align red-dot over distant object.

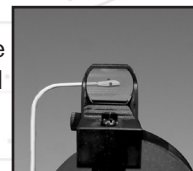

7) Point the telescope at a bright object

- The Moon an ideal target for this.



8) Focus the telescope until image is sharp.

- Enjoy the view!



Always use the EclipseView Solar Filter when viewing at or near the Sun or irreversible eye damage may occur.

Attaching Your Accessories

Installing the Red-dot Finder

An eyepiece has a narrow field of view. A red-dot viewfinder has a wider field of view, which makes it easier to locate objects. Once the red-dot viewfinder is aligned to the optical tube, the red-dot can be used to locate and place objects more easily in the telescope's eyepiece.

STEP 1: Remove the two thumbscrews from the optical tube.

STEP 2: Take the red-dot viewfinder and place the bracket onto the threaded screws, with the viewfinder lens forward towards the front of the telescope.

STEP 3: Use the two thumbscrews to secure the red-dot viewfinder bracket to the optical tube. Tighten to a firm feel.



Attaching Your Accessories

Inserting An Eyepiece

Magnification, or power is based on eyepiece focal length. The higher power will present a larger, dimmer image, with smaller field of view. The lower the power, the brighter and smaller the image will be, with a wider field of view.

STEP 1:

EclipseView60 Models: Slide the MA 26mm eyepiece into diagonal prism.

EclipseView76 Models: Slide the MA 26mm eyepiece directly into the focuser drawtube.

STEP 2: Tighten the **eyepiece holder thumbscrews** to hold the eyepiece securely.

Step 1



Step 1



Expert's Tip

When locating objects it is always best to start with the lower power (26mm) eyepiece. The 26mm has a wide viewing field that will allow objects to be more easily found. Once located and centered, you can switch to a higher power eyepiece such as a 9mm to increase the viewing power. The higher power will present a larger, dimmer image, with smaller field of view.

Aligning The Red-Dot Viewfinder

Aligning the red-dot viewfinder allows you to accurately point at the same location as the telescope. It is recommended that you perform steps 1 and 2 during the day and step 3 during nighttime.

NOTE: THE RED-DOT FINDER IS ONLY FOR NIGHTTIME USE AND SHOULD NEVER BE USED AT OR NEAR THE SUN.

STEP 1: Point telescope at an easy-to-find target.

NOTE: DO NOT EVER POINT AT OR NEAR SUN WITHOUT THE PROPER SOLAR FILTER INSTALLED!

STEP 2: Look through the 26mm eyepiece and turn the focuser knob until the image is sharply focused. Center the object precisely in the eyepiece's field of view.

STEP 3: Turn on the red-dot viewfinder by turning the on/off switch clockwise.

Step 2.



Step 3.



Aligning The Red-Dot Viewfinder

STEP 4: Look through the red-dot viewfinder. Turn one or both of the viewfinder's alignment screws until the red-dot is precisely over the same object as you centered in the eyepiece. The side alignment screw controls the horizontal, while the rear alignment screw controls the vertical.

STEP 5: When finished, turn off the red-dot viewfinder by rotating the on/off switch counter-clockwise.

STEP 6: Check this alignment at night on a celestial object, such as the Moon or a bright star, and use the viewfinder's alignment screws to make any necessary refinements. Once they are aligned and pointing at the same location, use the red-dot viewfinder to locate objects by placing the red-dot over the object. Then use the 26mm eyepiece to view the object.

Step 4.



Step 5.



Moving The Telescope

Your telescope is alt-azimuth mounted. Alt-azimuth is just a complicated way of saying that your telescope moves up and down and from side to side. Other telescopes may be mounted in different ways.

STEP 1: Slightly loosen both of the star-shaped altitude lock knobs and slow-motion rod lock knob. Loosening these knobs allow you to move the telescope up and down.

STEP 2: Slightly loosen the azimuth lock knob. Loosening this lock allows the telescope to be moved from side to side.

STEP 3: Once an object is found, re-tighten the control knobs. You can then use the slow motion control to make smooth and precise movements as you can follow (or “track”) an object vertically as it moves in the eyepiece.

STEP 4: To use the slow-motion control feature aim the telescope at an object and tighten the control knobs. Then lock the altitude lock knob and rotate the slow-motion control to follow the target in the vertical direction.

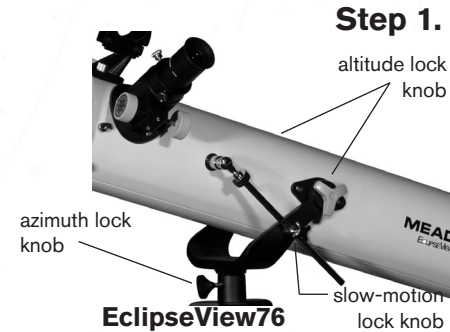
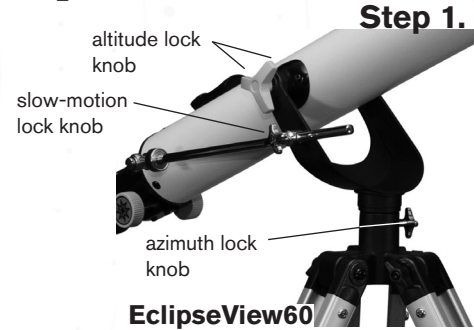

How To Use Your Telescope

Step 1

Pick an object in the sky that you want to view, and make sure you are using the 26mm eyepiece. If viewing the Sun, make sure to install the Solar Filter & SunFinder.

Step 2

Turn the red-dot finder on (if installed). Adjust the altitude lock knob as needed and take aim at the object using your red-dot viewfinder.

Step 3

When the red-dot or SunFinder is placed over the object, tighten the altitude lock knob to secure the optical tube in place.

Step 4

Look through the eyepiece to see if the object is in view and center it, if necessary.

Step 5

Gently adjust the focus in or out until you have a crisp, clean image.

Step 6

Try out the different eyepieces to get a closer look at the object.

Observing At Night

**We have one very important rule that you should always follow when using your telescope:
Have Fun!**

Have a good time when you're observing. You may not know everything that there is to know about a telescope or what all the sights in the universe are, but that's OK. Just point and observe at first. You will enjoy your telescope the you practice and learn more about it. Galileo, who is one of the first astronomers to use a telescope, discovered four of the moons of Jupiter with a telescope about the same size as yours- and his didn't even focus very well!

Don't be scared off by difficult terms or complicated procedures. Don't panic! Just relax and enjoy your scope. Utilize the internet and books to learn about constellations, stars, planets and the hobby overall.



**Don't
stress
Have fun!**



Observing The Moon

The Moon is the best object to observe the first time you go out at night. Pick a night when the Moon is a crescent. No shadows are seen during a full Moon, making it appear flat and uninteresting. Look for different features on the Moon.

The most obvious features are craters. In fact you can see craters within craters. Some craters have bright lines about them. These are called rays and are the result of material thrown out of the crater when it was struck by a colliding object. The dark areas on the Moon are called maria and are composed of lava from the period when the Moon still had volcanic activity. You can also see mountain ranges and fault lines on the Moon.



Observing The Solar System

Venus is seen before dawn or after sunset, because it is close to the Sun. You can observe Venus going through crescent phases. But you cannot see any surface detail on Venus because it has a very thick atmosphere of gas. When Mars is close to the Earth, you can see some details on Mars, and sometimes even Mars' polar caps. Jupiter is quite interesting to observe. You can see bands across the face of Jupiter.

The more time you spend observing these bands, the more details you will be able to see. One of the most fascinating sights of Jupiter are its moons. The four largest moons are called the Galilean moons, after the astronomer Galileo, who observed them for the first time. If you've never watched the Galilean moons in your telescope before, you're missing a real treat!

Each night, the moons appear in different positions around the Jovian sky. This is sometimes called the Galilean dance. On any given night, you might be able to see the shadow of a moon on the face of Jupiter, see one moon eclipse another or even see a moon emerge from behind Jupiter's giant disk. Probably the most memorable sight you will see in your telescope is Saturn. Although you may not see many features on the surface of Saturn, its ring structure will steal your breath away. On nights of very steady seeing you may be able to see a black opening in the rings, known as the Cassini band.



Observing The Beyond

Once you have observed our own system of planets, it's time to really travel far from home and look at stars and other objects. You can observe thousands of stars with your telescope. At first, you may think stars are just pinpoints of light and aren't very interesting. But look again. There is much information that is revealed in stars. The first thing you will notice is that not all stars are the same colors. See if you can find blue, orange, yellow, white and red stars. The color of stars sometimes can tell you about the age of a star and the temperature that they burn at.

You may be able to see the Andromeda galaxy and several others in your telescope. They will appear as small, fuzzy clouds. Only a very large telescope will reveal spiral or elliptical details.

You will also be able to see some nebulas with your scope. Nebula means cloud. Most nebulas are clouds of gas. The two easiest to see in the Northern Hemisphere are the Orion nebula during the winter and the Trifid nebula during the summer. These are large clouds of gas in which new stars are being born. Some nebulas are the remains of stars exploding. These explosions are called supernovas.

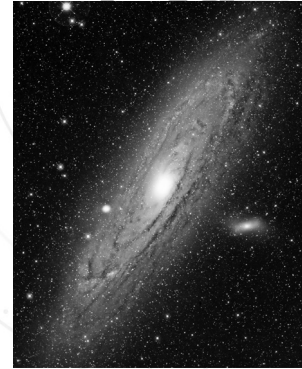

Resources

STAR CHARTS

Star charts and planispheres are useful for a variety of reasons. They are a great aid in planning a night of celestial viewing. A wide variety of star charts are available in books, in magazines, on the internet, apps and CD Roms. Meade offers AutoStar Suite™ software (contact your local dealer or visit Meade.com).

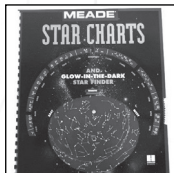

Astronomy and Sky and Telescope magazines print star charts each month for up-to-the-minute maps of the heavens. Apps like SkyWeek or Star Chart are great for on-the-go information.

MAGAZINES

Astronomy
magazine

SKY
& TELESCOPE

SkyNews

WEB LINKS

- **The Meade 4M Community:**
<http://www.meade4m.com>
- **Sky & Telescope:**
<http://www.skyandtelescope.com>
- **Astronomy:**
<http://www.astronomy.com>
- **Astronomy Picture of the Day:**
<http://antwrp.gsfc.nasa.gov/apod>
- **Photographic Atlas of the Moon:**
http://www.lpi.ursa.edu/research/lunar_orbiter
- **Hubble Space Telescope Public Pictures:**
<http://opposite.stsci.edu/pubinfo/pictures.html>

APPS



Meade SkyKey



Meade StellaAccess

Tips And Tricks

If viewing at night, let your eyes “dark-adapt”: Allow five or ten minutes for your eyes to become “dark adapted” before observing. Use a red filtered flashlight to protect your night vision when reading star maps, or inspecting the telescope. Stay away from bright lights too. Do not use a regular flash-light or turn on other lights when observing with a group of other astronomers.

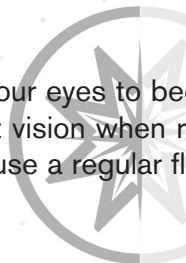

EYEPIECES

Always begin your observations using the 26mm low-power eyepiece. The 26mm eyepiece delivers a bright, wide field of view and is the best to use for most viewing conditions. Use the high-power 9mm eyepiece to view details when observing the Moon and planets. If the image becomes fuzzy, switch back down to a lower power. Changing eyepieces changes the power or magnification of your telescope. Optional Accessory Barlow lens: You can also change magnification by using a Barlow lens. The Barlow lens doubles the power of your telescope.

OBJECTS MOVE IN THE EYEPIECE



If you are observing an astronomical object, you will notice that the object will begin to move slowly through the telescopic field of view. This movement is caused by the rotation of the Earth and makes an object move through the telescope’s field of view. To keep astronomical objects centered in the field, simply move the telescope on one or both of its axes—vertically and/or horizontally as needed. Use the altitude slow-motion control rod to accurately move the telescope vertically in a controlled motion. At higher powers, astronomical objects will seem to move through the field of view of the eyepiece more rapidly.

Tips And Tricks

THINGS THAT AFFECT VIEWING



VIBRATIONS: Avoid touching the eyepiece while observing through the telescope. Vibrations resulting from such contact will cause the image to move. Avoid observing sites where vibrations cause image movement.



LIGHT POLLUTION: Light pollution is excessive, misdirected, or artificial outdoor light. Too much light pollution has consequences: it washes out starlight in the night sky, interferes with astronomical research, disrupts ecosystems, has adverse health effects and wastes energy.



OBSERVING CONDITIONS: Planets and other objects viewed low on the horizon often lack sharpness—the same object, when observed higher in the sky, will appear sharper and have greater contrast. Be aware of your climate and surroundings at your observing location. Viewing conditions such as humidity and atmospheric turbulence can negatively impact your observations.



VIEWING THROUGH WINDOWS: Avoid setting up the telescope inside a room and observing through an opened or closed window pane. Images may appear blurred or distorted due to temperature differences between inside and outside air. Also, it is a good idea to allow your telescope to reach the ambient (surrounding) outside temperature before starting an observing session.

Calculating Magnification

The power of a telescope is how much it magnifies objects. Each telescope has its own set of focal lengths and, therefore, different magnifications when used with various eyepieces. For example, the EclipseView 60mm used with the 26mm eyepiece magnifies an object 31 times. The 9mm eyepiece used with the EclipseView 60mm will magnify objects 89 times. You can calculate how much magnification an eyepiece will have with your specific telescope. Just divide the telescope focal length by the focal length of the eyepiece.

$$\begin{array}{l} \text{Focal Length of the Telescope} \\ \div \\ \text{Focal Length of the Eyepiece} \\ = \text{Magnification} \end{array}$$

Look at the specifications. For example, you will see that the focal length of the EclipseView 60mm is 800mm. Let's say that you have obtained a 6.3mm eyepiece. You can tell what the focal length of your eyepiece is as it is always printed on the side of the eyepiece. Divide: 800mm \div 6.3mm, which equals 126.98. Round this off to the nearest whole number and you find the 6.3mm eyepiece used with the EclipseView 60mm magnifies objects 127 times.

Eyepiece's magnification x 2

= Magnification with a 2X Barlow lens

If you use a Barlow lens with one of your eyepieces, it doubles the magnification of your eyepiece. Other types of Barlows can triple or further increase the power of an eyepiece. To find out how much your magnification is when you use a 2x Barlow, multiply your eyepiece's magnification by two. For example, the 9mm low-power eyepiece used with the EclipseView 60mm magnifies an object 89 times. Multiply 89 by 2 and you get 178 times magnification with a Barlow.

Expert's Tip

It's worth repeating: Keep in mind that a bright, clear, but smaller image is more interesting than a larger, dimmer, fuzzy one. Using too high a power eyepiece is one of the most common mistakes made by new astronomers. So don't think that higher magnification is necessarily better—quite often the best view is with a lower magnification value!

Collimation

EclipseView76 Models Only

What is collimation?

All Meade EclipseView Reflecting telescopes are optically aligned at the factory prior to shipment. It is unlikely that you will need to align, or collimate, the optics after receipt of the instrument. However, if the telescope received unusually rough handling in shipment, it is possible that the optics must be re-aligned for best optical performance.

Figure 3 shows the **Primary Mirror Cell** (114 models only), the three **primary mirror tilt screws** (fig.3,#2), and the **primary mirror cell locking knobs** (fig.3,#3). The **primary mirror tilt screws** adjust the tilt-angle of the mirror, and the **primary mirror cell locking knobs** locks the mirror in place.

Figure 4 shows the **Secondary Mirror Assembly** and the three **secondary mirror collimation screws** (fig. 4, #2). These screws allows for adjustments of the secondary mirror assembly.

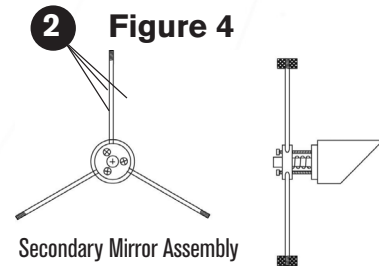
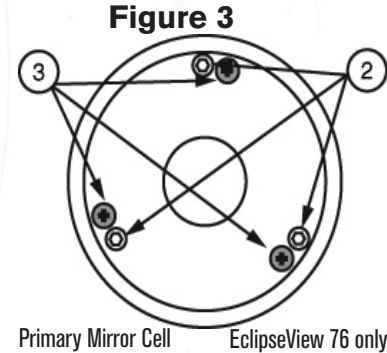

Collimation

EclipseView76 Models Only

CORRECT COLLIMATION:

The properly collimated (aligned) mirror system in the Meade EclipseView telescope assures the sharpest images possible. This occurs when the primary mirror and secondary mirror are tilted so that the focused image falls directly through the center of the focuser draw tube. To inspect the view of the mirror collimation, look down the focuser draw tube with the eyepiece removed.

The edge of the **focuser drawtube** (fig. 5, #1), will frame the reflections of the primary mirror with the **3 mirror clips** (fig. 5, #2), the **secondary mirror** (fig. 5, #3), the **spider vanes** (fig. 5, #4), and **your eye** (fig. 5, #5). Properly aligned, all of these reflections will appear concentric (i.e., centered) as illustrated in **Figure 5**. Any deviation from the concentric reflections will require adjustments to the **secondary mirror assembly** (fig. 4) and/or the **primary mirror cell** (fig. 3).

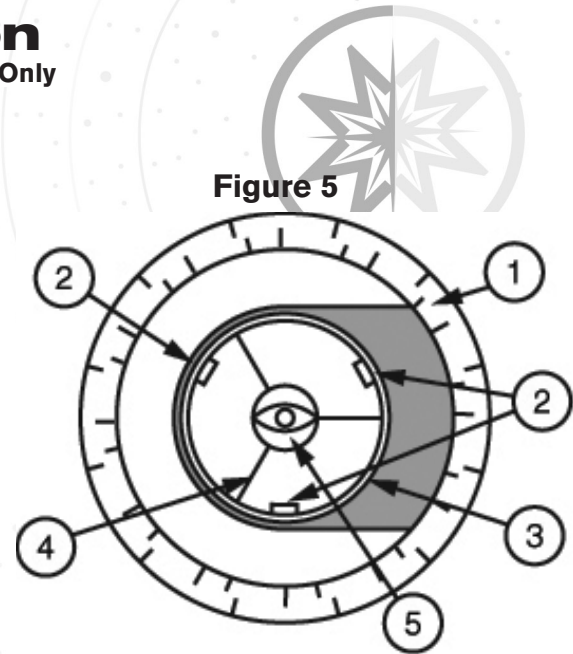

Figure 5

Collimation

EclipseView76 Models Only

SECONDARY MIRROR HOLDER ADJUSTMENTS:

If the **secondary mirror** (fig. 6, #1) is centered in the **draw tube** (fig. 6, #2), but the **primary mirror** is only partially visible in the reflection (fig. 6, #3), one or more of the 3 **secondary mirror collimation screws** need adjusting. First, unthread each of the secondary mirror collimation screws slightly to the point of where you can tilt the secondary holder from side-to-side.

By grasping the secondary holder with your hand, tilt the secondary mirror holder until you see the primary mirror become as centered in the reflection of the diagonal mirror as possible. Once you are at the best position, thread in the 3 **secondary mirror collimation screws** to lock the holder in place. Then, if necessary, make adjustments to these 3 screws to refine the tilt-angle of the secondary mirror until the entire primary mirror can be seen centered within the secondary mirror reflection. When the secondary mirror is correctly aligned, it will look like Figure 7.

Figure 6

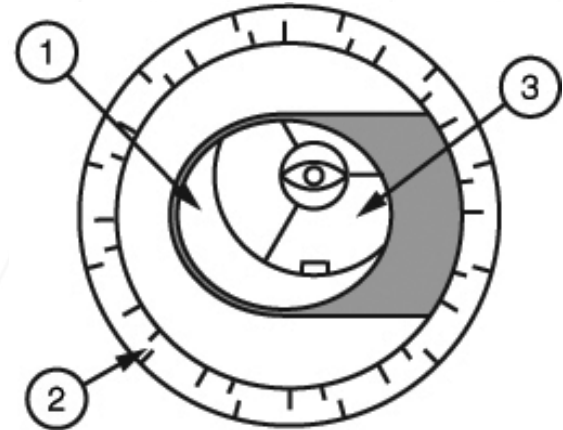

Note: The primary mirror is shown out of alignment.

Collimation

EclipseView76 Models Only

PRIMARY MIRROR ADJUSTMENTS

If the **secondary mirror** (fig. 7, #1) and the reflection of the **primary mirror** (fig. 7, #2) appear centered within the **draw tube** (fig. 7, #3), but the reflection of your eye and the reflection of the **secondary mirror** (fig. 7, #4) appear off center, you will need to adjust the **primary mirror tilt screws** (fig. 3, #2) of the **primary mirror cell**. These **primary tilt screws** are located behind the **primary mirror**, at the lower end of the **main tube**.

To adjust the **primary mirror tilt screws** (fig. 3, #2), first turn by several turns, the **primary mirror cell lock knobs** (fig. 3, #3) that are next to each **primary mirror tilt screw**. The three **primary mirror cell locking screws** are slotted head screws on the EclipseView 114 models. Then by trial-and-error, turn the **primary mirror tilt knobs** (fig. 3, #2) until you develop a feel for which way to turn each knob to center the reflection of your eye. Once centered, as in **Figure 5**, turn the 3 **primary mirror cell locking screws** (fig. 3, #3) to re-lock the tilt-angle adjustment.



Figure 7

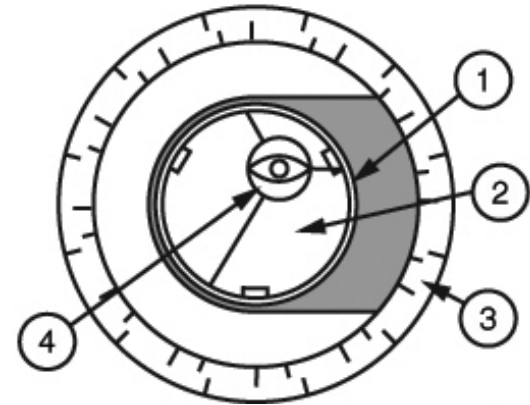

Collimation

EclipseView76 Models Only

With the collimation performed, you will want to test the accuracy of the alignment on a star. Use the 26mm eyepiece and point the telescope at a moderately bright (second or third magnitude) star, then center the star image in the telescope's field-of-view. With the star centered follow the method below:

- Bring the star image slowly out of focus until one or more rings are visible around the central disc. If the collimation was performed correctly, the central star disk and rings will be concentric circles, with a dark spot dead center within the out-of-focus star disk (this is the shadow of the **secondary mirror**), as shown in **Figure 10**. (An improperly aligned telescope will reveal elongated circles (**fig. 8**), with an off-center dark shadow.)

- If the out-of-focus star disk appears elongated (**fig. 8**), you will need to adjust the **primary mirror** adjusting tilt screws of the **primary mirror cell** (fig. 3, #3)

- To adjust the **primary mirror tilt screws**, first unscrew several turns the 3 slotted-head **primary mirror cell locking screws** (fig. 3, #2), to allow free turning movement of the tilt knobs.

Figure 8

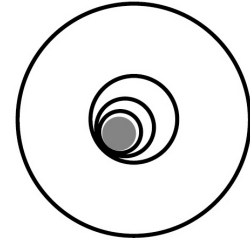
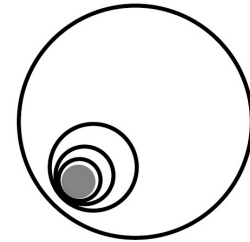

Figure 9



Collimation

EclipseView76 Models Only

- Move the telescope until the star image is at the edge of the field-of-view in the eyepiece, as in **Figure 9**.

- As you make adjustments to the **primary mirror tilt screws** (fig. 3, #3), you will notice that the out-of-focus star disk image will move across the eyepiece field. Choose one of the 3 **primary mirror tilt screws** and slightly move the shadow to the center of the disk. Then slightly move the telescope to center the star disk image in the center of the eyepiece.

- If any further adjustments are necessary, repeat this process as many times as needed until the out-of-focus star disk appears as in **Figure 10**, when the star disk image is in the center of the eyepiece field.

- With the star testing of the collimation complete, tighten the 3 slotted-head **primary mirror locking screws** (fig. 3, #2)

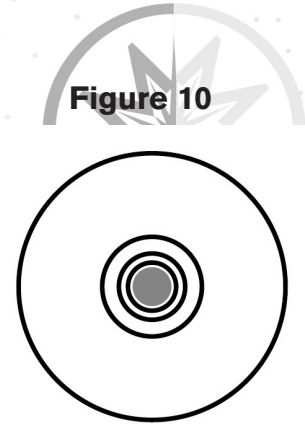

Meade also sells a Laser Collimator accessory that will simplify collimation of the optics. This device works by shining a red laser onto the optics and viewing the reflected light. If the reflected light beam is not centered on the device, it can be easily adjusted using the telescope adjustments until the beam is centered.

Viewfinder Battery

If the viewfinder red-dot does not illuminate, verify the viewfinder is on by rotating the power switch (fig 1, #15) below the viewfinder lens clockwise.

If the red-dot does not illuminate, the battery may need replacing. To replace the battery, press the left side of the viewfinder housing labeled “push”. The battery compartment will slide out on the right side of the viewfinder (see **Figure 11**).

Replace the battery with a Lithium CR2032 battery with the positive side up. Then push the battery compartment back into the viewfinder and power on.

Figure 11



Care And Maintenance



Your telescope is a precision optical instrument designed for a lifetime of rewarding viewing. It will rarely, if ever, require factory servicing or maintenance. Follow these guidelines to keep your telescope in the best condition:

As with any quality instrument, lens or mirror surfaces should be cleaned as infrequently as possible. Telescope optics should be cleaned only when absolutely necessary. In all cases avoid touching any mirror surface. A little dust on the surface of a mirror or lens causes negligible loss of performance and should not be considered reason to clean the surface. When lens or mirror cleaning does become necessary, use a camel's hair brush or compressed air gently to remove dust. If the telescope's dust cover is replaced after each observing session, cleaning of the optics will rarely be required.

Fingerprints and organic materials on the lens or mirror may be removed with a solution of 3 parts distilled water to 1 part isopropyl alcohol. You may also add 1 drop of biodegradable dishwashing soap per pint of solution. Use soft, white facial tissues and make short, gentle strokes. Change tissues often.



CAUTION: Do not use scented or lotioned tissues or damage could result to the optics.
DO NOT use a commercial photographic lens cleaner.

Accessories

For an up-to-date list of compatible Meade accessories, contact your Meade Dealer or see the Meade online catalog for more information. Visit us on the web at www.meade.com.

ADDITIONAL EYEPIECES: (1.25" barrel diameter only): For higher or lower viewing magnifications, Meade's eyepieces are available in a wide variety of focal lengths and provide a high level of image resolution and color correction at economical prices. Available as individual eyepieces or in sets with carry case!

COLOR/MOON FILTERS: Meade Color filters permit observation of planetary/lunar surface detail that is often virtually invisible without filtration. Choose the filter or filter set that best meet your needs and see what you have been missing!

BARLOW LENS: The Meade 2x or 3x Barlow doubles or triples the magnification of your 1.25" eyepieces. The 2x is our most popular Barlow due to its excellent quality, value, and usefulness on nearly every model telescope sold.

LASER COLLIMATOR: Easily and quickly align your telescope optics! May be used on any standard Newtonian reflector telescope where the optical system contains two independently adjustable mirrors. Features adjustable brightness. Powered from a single CR2032 type battery (included).

**Eyepiece
Kit & filters**



Barlow Lens



Laser Collimator



Recycling



CORRECT DISPOSAL OF THIS PRODUCT

(Waste Electrical & Electronic Equipment)

This marking shown on the product or its literature indicates that it must not be disposed of in unsorted municipal waste at the end of its working life.

To prevent possible harm to the environment or human health from uncontrolled waste disposal, please separate this from other types of wastes and recycle it as required by law. Household users should contact either the retailer where they purchased this product, or their local government office, for details of where and how they can take this item for environmentally safe recycling. Business users should contact their supplier and check the terms and conditions of the purchase contract. This product should not be mixed with other commercial wastes for disposal.

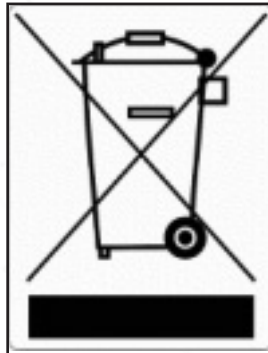

Customer Service And Warranty

MEADE CUSTOMER SERVICE:

Have a question concerning your telescope? Call Meade Instruments Customer Service Department! We're happy to help.

Before returning the telescope to the factory, call the Meade Customer Service Department first as most problems can be solved over the phone. Make sure to give a full description of the problem, as well as your name, address, and daytime telephone number. The great majority of servicing issues can be resolved by telephone, avoiding return of the telescope to the factory.

CONTACT US

By Phone:
800-626-3233
M-F; 7AM-4PM PST

Via email:
customerservice@meade.com

MEADE LIMITED TIME WARRANTY:

Every Meade telescope, and telescope accessory is warranted by Meade Instruments Corp. ("Meade") to be free of defects in materials and workmanship for a period of ONE YEAR from the date of original purchase in the U.S.A. Meade will repair or replace a product, or part thereof, found by Meade to be defective, provided the defective part is returned to Meade, freight-prepaid, with proof of purchase. This warranty applies to the original purchaser only and is nontransferable. Meade products purchased outside North America are not included in this warranty, but are covered under separate warranties issued by Meade international distributors.

Customer Service And Warranty



RG A NUMBER REQUIRED:

Prior to the return of any product or part, a Return Goods Authorization (RGA) number must be obtained from Meade by writing, or by calling (800) 626-3233.

Each returned part or product must include a written statement detailing the nature of the claimed defect, as well as the owner's name, address, and phone number.

This warranty is not valid in cases where the product has been abused or mishandled, where unauthorized repairs have been attempted or performed, or where depreciation of the product is due to normal wear-and-tear.

Meade specifically disclaims special, indirect, or consequential damages or lost profit which may result from a breach of this warranty. Any implied warranties which cannot be disclaimed are hereby limited to a term of one year from the date of original retail purchase. This warranty gives you specific rights. You may have other rights which vary from state to state.

Meade reserves the right to change product specifications or to discontinue products without notice. This warranty supersedes all previous Meade product warranties.

OBSERVATION LOG

OBSERVER: _____

OBJECT NAME: _____

DATE & TIME OBSERVED: _____

CONSTELLATION: _____

EYEPIECE SIZE: _____

SEEING CONDITIONS: EXCELLENT GOOD POOR

NOTES:

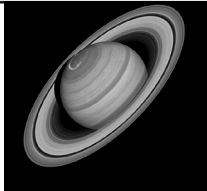

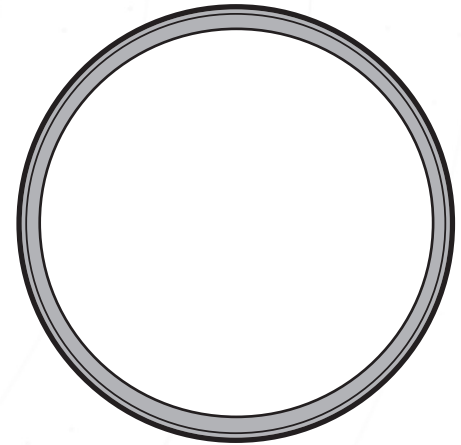

DRAWING OF IMAGE

OBSERVATION LOG

OBSERVER: _____

OBJECT NAME: _____

DATE & TIME OBSERVED: _____

CONSTELLATION: _____

EYEPIECE SIZE: _____

SEEING CONDITIONS: EXCELLENT GOOD POOR

NOTES:



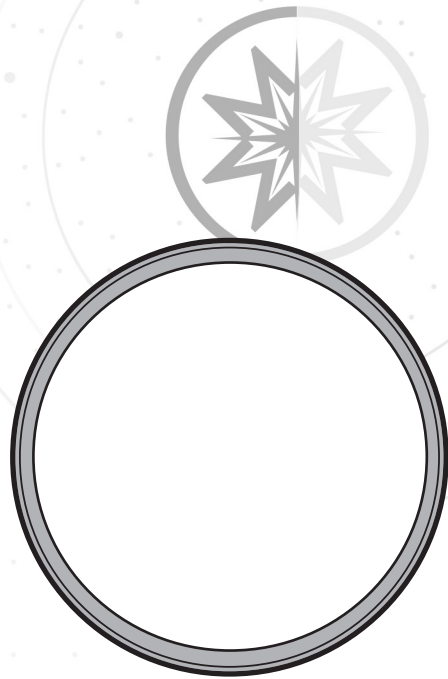

DRAWING OF IMAGE

OBSERVATION LOG

OBSERVER: _____

OBJECT NAME: _____

DATE & TIME OBSERVED: _____

CONSTELLATION: _____

EYEPIECE SIZE: _____

SEEING CONDITIONS: EXCELLENT GOOD POOR

NOTES:



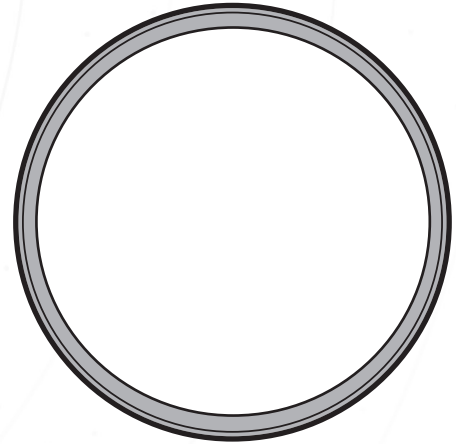

DRAWING OF IMAGE

We appreciate your business. Keep in touch!



Let's Get Social:



@MeadeInstruments



@Meadetelescopes



@MeadeInstrument

Share your photos with us:

#MeadePhotos
Social@meade.com

For special offers and other products, visit our website:

www. meade.com



1-800-626-3233

Meade Instruments
27 Hubble
Irvine, CA 92618

20170120 REV1