



ECLIPSE VIEW™

10x50 BINOCULARS

INSTRUCTIONS



SUN WARNING!

CAUTION: NEVER look through your binoculars at or near the Sun until the solar filters are securely installed at the front of the binoculars. Please read the following instructions fully and keep them in mind when observing the Sun. Always use caution when viewing at or near the Sun. Adult Supervision is required.

Inspecting the Solar Filter:

All filters are checked carefully before shipment. However, as the solar filter material is delicate, be sure to check for any damage prior to each use.

Inspecting Solar Filters:

Before installing the solar filter, hold the solar filter up to the sky away from the Sun or use a standard 60 to 100 watt light bulb. Examine the filter for any pin holes, scratches, tears, or signs the filter material has separated



from its holder. If any damage is seen, do not use the solar filter. Replacement will be required.

Installing the Solar Filter:

The solar filters are pre-installed at our factory to allow use right out of the box. However, if the solar filters are removed from the binoculars make sure to reinstall the filters before looking at or near the Sun. To install the filters, do the following.

1. Point the binoculars upwards away from the Sun.
2. Carefully slide the filters fully over the front end of the binocular lens. Never force the filter onto the binoculars or damage can occur.

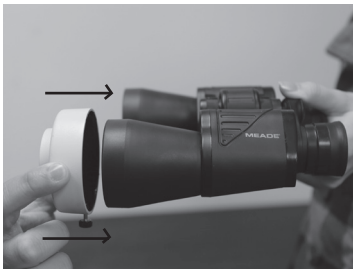

Step 2 SLIDE THE FILTER ON:



Step 3 TIGHTEN THUMB SCREW:

3. Tighten the thumb screw located on side the filter until firm. Do this for both filters. Do not overtighten the thumb screw.

STEP 4 BOTH FILTERS INSTALLED:



4. The solar filters are now installed and ready to use on the Sun. Always use caution when viewing at or near the Sun.

5. When removing the solar filters, point the binoculars away from the Sun first, then remove the filters. Removing the filters while the binoculars are still pointed at the Sun is very dangerous and can cause serious damage to the binoculars or anyone that may unknowingly attempt to look through the now unfiltered binoculars

Observing the Sun:

What makes our Sun so enjoyable to observe is that it's an active star that's always changing. When viewing the Sun through the EclipseView solar filters, the Sun will show up as a yellow-orange disk with possible Sunspots on its surface.

Sunspots are temporary dark regions on the Sun where the surface temperature is cooler than the surrounding material. They are places where the Sun's ever-changing magnetic field prevents the hotter material from below from reaching the surface. Sunspots are continuously changing on a daily basis, sometimes even on an hourly basis and always occur in pairs just like the North & South Pole of a magnet. When viewing Sunspots you will notice they always have different shapes and sizes where no two Sunspots are the same.

Our Sun goes through an eleven year cycle where its surface activity increases dramatically. During increased surface activity, many Sunspots can be observed near the solar equator. As the solar activity increases, Sunspots typically will be seen closer to the Sun's north and south poles. During periods of low surface activity, the number of Sunspots will reduce drastically and often no Sunspots will be visible at all.

As the number of Sunspots are constantly changing, don't get discouraged if you don't see any Sunspots when observing the Sun. Check back again on another day, and look carefully on the solar surface. How many Sunspots do you see each day?

Planetary transits are another exciting feature to see when observing the Sun. Although this event happens infrequently, it occurs when the planet Mercury or Venus passes in front of the Sun. From your EclipseView binoculars this would look like a small black dot travelling very slowly across the face of the Sun. These rare planetary transits are well known in advance and often mentioned on the local news days before they occur.

Solar Eclipses occur when the Moon, during its monthly trip around the Earth, passes between the Earth and the Sun. This causes the Moon's shadow to be cast onto a small part of the Earth. This shadow will have two distinct regions, the innermost and darkest region called the umbra and the outer brighter region called the penumbra. The dark umbra region is a very narrow region sometimes 60 - 100 miles wide. The penumbra region covers a much larger area and can be almost 4,000 miles wide.

There are three different types of solar Eclipses:

A Partial Solar Eclipse occurs when the Moon passes in front of the Sun and blocks only a portion of the Sun. This is the most common type of solar eclipse. The Sun will look

like a bite has been taken out of it.

An Annular Solar Eclipse occurs when the Moon passes directly in front of the Sun, but only blocks the central portion of the Sun. During this type of eclipse, the Moon is a smaller apparent size than the Sun and cannot completely block the Sun. As a result, the Sun's entire edge, or annular region, is still visible around the Moon.

A Total Solar Eclipse occurs when the Moon passes directly in front of the Sun, blocking the entire solar disk. During this type of eclipse, the Moon and Sun overlap completely and observers located in the shadows darker umbra region will experience "totality". During "totality", or maximum blockage, the daytime sky can noticeably darken in a matter of minutes. This is the most prized of all solar eclipses and few people see this in their lifetime.

The partial, annular, and total solar eclipses are events you don't want to miss!

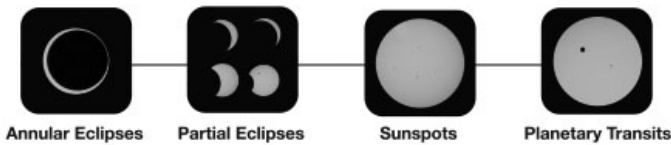

How to Observe a Solar Eclipse:

CAUTION: NEVER look through your binoculars at or near the Sun until the solar filters are securely installed at the front of the binoculars. Please read the following instructions fully and keep them in mind before observing the Sun. Always use caution when viewing at or near the Sun. Adult Supervision is required.

To view the solar eclipse, make sure you have the front EclipseView solar filters installed. Never look at the Sun without the solar filters installed or severe damage to your eyes can occur, including blindness.

The view through the EclipseView Solar filters should be comfortable, and not excessively bright. If the view through the filter is uncomfortable or excessively bright, stop using the filters immediately!

Choose an observing site with a clear view of the sky and as close to the umbra shadow region as possible. Often, people travel to locations where the solar eclipse will be most intense and weather will be clear.

Choose an observing location on grass and away from asphalt and concrete. Viewing over grass will reduce the amount of heat currents seen and give a better image quality.

The solar eclipse can last several hours from start to finish so make sure you have Sunblock, head covering or shaded place where you can get out of the bright Sun when needed.



Check the weather! Nothing can spoil a solar eclipse like clouds or rain.

You can also observe the Sun with special Mylar solar glasses, which you can purchase from Meade or at online retailers. The filters on these solar glasses are made of solar

safe material, similar to that found on the EclipseView solar filter. In addition to using your EclipseView Binoculars there are also indirect ways to view the Sun as well. A quick Google search will yield many different ideas.

Just remember to never look at or near the Sun without the proper solar filters!

Solar Filter Maintenance:

The solar filters can be cleaned by using a soft micro-fiber cloth, soft brush, or soft blower. First, gently blow off any dust that may accumulate on the filter from outside use. If the filter is still dirty than you may use a soft brush or micro-fiber cloth to remove the debris by gently wiping away the dust or debris. Do not clean with water or other liquids.

Please keep in mind that the solar filter film can be sensitive and the film can be scratched or damaged easily. The solar filter should be handled with care at all times to ensure safety when in use. This will also minimize accidental damage.

When the filters are not in use, store in a cool dry place.

Safety Compliance:

The EclipseView solar filter meets the following safety and compliance standards:

- Meets the requirements for ISO 12312-2:2015
- “CE” certified to the transmission requirements of scale 12-16 of EN 169/1992
- Meets the 2012 Transmission Requirements of EN 1836:2005 & AS/NZS 1338.1:1992 for Eclipse filters

MEADE LIMITED WARRANTY

Every Meade White-Light Solar Filter is warranted by Meade Instruments Corp (“Meade”) to be free of defects in materials and workmanship for a period of ONE YEAR from the date of original purchase in the U.S.A. Meade will repair or replace a product, or part thereof, found by Meade to be defective, provided the defective part is returned to Meade, freight-prepaid, with proof of purchase. This warranty applies to the original purchaser only and is non-transferable. Meade products purchased outside North America are not included in this warranty, but are covered under separate warranties issued by Meade international distributors. RGA Number Required: Prior to the return of any product or part, a Return Goods Authorization (RGA) number must be obtained from Meade by writing, or by calling (800) 626-3233. Each returned part or product must include a written statement detailing the nature of the claimed defect, as well as the owner's name, address, and phone number. This warranty is not valid in cases where the product has been abused or mishandled, where unauthorized repairs have been attempted or performed, or where depreciation of the product is due to normal wear-and-tear. Meade specifically disclaims special, indirect, or consequential damages or lost profit which may result from a breach of this warranty. Any implied warranties which cannot be disclaimed are hereby limited to a term of one year from the date of original retail purchase. This warranty gives you specific rights. You may have other rights which vary from state to state. Meade reserves the right to change product specifications or to discontinue products without notice. This warranty supersedes all previous Meade product warranties.

Instructions For the Proper Use and Care of Your Meade Binoculars (NO FILTERS)

Your Meade binocular is designed to deliver optimal performance for maximum viewing enjoyment. Regardless of your application — bird watching, nature studies, following spectator sports or sight seeing — you will appreciate the superior optics and durable construction that make Meade binoculars an excellent investment.

To protect your investment and ensure that you can take full advantage of the many features of your Meade binocular for many years to come, please take a few moments to review these instructions for proper use and care.

OVERVIEW OF YOUR MEADE BINOCULAR

To enhance your viewing enjoyment, please take a moment to familiarize yourself with your new Meade binocular:

EYE RELIEF FOR EYEGLASS WEARERS

For best results when viewing an object while wearing eyeglasses, fold down the rubber eyecups and place them against your glasses.

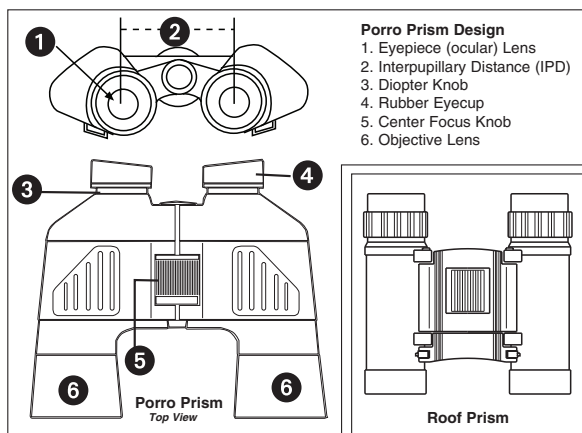

ADJUSTING THE EYEPIECES

The distance between your eyes is usually different than the distance between another person's eyes. This distance is known as the interpupillary distance, or IPD. Adjustment of your personal IPD is an important step in the proper use of your Meade binocular:

1. Hold the binocular up to your face in the normal viewing position, using both hands to hold each barrel firmly.
2. Pull the barrels apart or push the barrels together until you see a single circular field with both of your eyes.

FOCUSING THE BINOCULAR

1. Set the Diopter Knob (see diagram) at zero.
2. Look at an object that is approximately 100 feet (30m.) away.
3. With the lens cover or your hand, cover the right Objective Lens so that you will be looking through your left eye.
4. Rotate the Center Focus Knob until the object you are viewing with your left eye is sharp and clear. At this point the object is in focus.
5. Remove the lens cover (or hand) from the right Objective Lens and cover the left Objective Lens so that you will be looking through your right eye only.
6. While looking at the object, rotate the Diopter Knob until the object you see through your right eye is sharp and clear. At this point the object is in focus.
7. Now, with a simple turn of the Focus Knob, both far and near objects can easily be brought into focus.

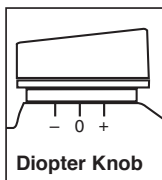

FOCUSING ZOOM BINOCULARS

Various Meade binoculars are designed to “zoom” — to move closer to or farther away from an object. To focus a zoom binocular, first set the power at its highest magnification, then simply follow the same binocular focusing instructions shown above. After the binocular is focused for your eyes at the highest power, simply move the zoom lever (see diagram) for focusing at lower powers. **NOTE:** Zoom binoculars typically provide better quality images at lower powers.

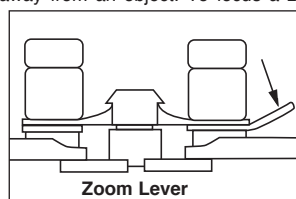

WATERPROOF / FOG PROOF MODELS

Select Meade binoculars offer protection against internal moisture condensation, humidity, and dust. Waterproof/fog proof binoculars have been nitrogen-purged to expel all internal moisture and atmosphere, and are then “O-Ring” sealed for the ultimate in protection in all weather conditions.

CARE AND CLEANING

Meade binoculars have been designed for use in rugged field conditions. By following these simple guidelines, your Meade binocular will provide optimal performance for many years:

1. Keep binocular lenses clean and free of moisture and dirt.
2. When not in use, do not expose your binoculars to direct sunlight for long periods of time (e.g. on the dashboard of your vehicle).
3. Store your binocular in a cool, dry place. Always store your binocular in its carrying case, with the rubber eyecups in the “up” position.
4. Binoculars are *precision* instruments — *handle them with care*. Do not drop, shake, bump or rattle your binocular. Its precision optics can become misaligned (out of collimation) as a result of rough treatment, which can render the instrument virtually unusable. Collimation problems usually require repair by a trained technician, and are generally **not** covered by the Warranty.

To clean your binocular, follow these simple steps:

1. Before attempting to clean any of the lenses, carefully remove all grit, sand, dirt, dust, or other substances which may scratch the surface of the optics. Avoid touching lens surfaces with fingers or coarse materials. Removal of foreign substances is best accomplished with a soft lens brush, lens cleaning tissue, a lint-free cotton cloth, a clean cotton swab, or “canned” air.
2. For materials that remain on the lenses, use a liquid substance designed to remove grease (e.g., commercial lens cleaner, household window cleaner or rubbing alcohol). **CAUTION: Do not apply liquid directly onto a lens, which may result in the liquid seeping into the barrel of the binocular.** Apply the solution onto a cloth or swab, and use the cloth or swab to remove the foreign substance with circular motions. Lens cleaning should not rub away anti-reflectant lens coatings; however, excessive, repeated pressure on dirty lenses or rubbing dirt into the lens surfaces will damage the coatings. **Use a light touch.**
3. Once the foreign substances have been removed from the lens surface, simply breathe onto the lenses to apply vapor. Before the moisture evaporates, polish the lens surface with a clean cotton cloth or lens cleaning cloth.
4. For a more thorough cleaning of your binocular: Remove dirt or liquid from under the eyecup flange (next to the lens surface) by removing the eyecup (by gently lifting it up) and carefully cleaning the entire lens surface as described above. When the lenses are fully cleaned, carefully replace the eyecups and avoid touching the surface of the lens with your fingers.

Meade Binocular Limited Lifetime Warranty

Every Meade binocular is warranted by Meade Instruments Corp (MIC) to be free of defects in materials and workmanship for the lifetime of the original purchaser. MIC will repair or replace the product, or part thereof, found upon inspection by MIC to be defective, provided the defective part or product is returned to MIC, freight prepaid, with proof of purchase. This warranty applies to the original purchaser only and is non-transferable. MIC products purchased outside North America are not included in this warranty, but are covered under separate warranties issued by Meade International Distributors.

RGA Number Required: Prior to the return of any product or part, a Return Goods Authorization (RGA) number must be obtained from Meade by writing, calling 800-626-3233 (7:00am to 4:00pm, Pacific Time Zone) or by sending an email to binocularsupport@meade.com. Each returned part or product must include a written statement detailing the nature of the claimed defect, as well as the owner's name, address, and phone number.

This warranty is not valid in cases where the product has been abused or mishandled, where unauthorized repairs have been attempted or performed, or where depreciation of the product is due to normal wear-and-tear. Meade specifically disclaims special, indirect, or consequential damages or lost profit, which may result from a breach of this warranty. Any implied warranties which cannot be disclaimed are hereby limited to a term of one year from the date of original retail purchase.

This warranty gives you specific rights. You may have other rights which vary from state to state. Meade reserves the right to change product specifications or to discontinue productions without prior notice. This warranty supersedes all previous Meade binocular warranties.

© The name “Meade,” and the Meade logo, are trademarks registered with the U.S. Patent Office and in principal countries throughout the world. All rights reserved.
 © 2017 Meade Instruments Corporation. Specifications subject to change without notice.